

MUSTAD HOOFCARE CENTER

# PRODUCT CATALOG



PRODUCTS WITH A REPUTATION YOU TRUST



## WE HAVE THE PRODUCTS YOU NEED, ALL IN ONE PLACE.

Mustad is a family of companies and leading brands that is rich in heritage and tradition; offering the farrier industry the finest products. We are proud of our investment in farrier-related interests and our ongoing commitment to farrier schools, along with our worldwide sponsorship and participation in industry events and contests. The feedback we receive via e-mail, letters, and phone calls is invaluable as a means to improve our products and services. Many of the changes that have taken place over the past several years to our nails, shoes, and tools are the direct result of ideas from farriers on what they need to more efficiently do their job.

### Capewell Horseshoe nails

---

Inventor George J. Capewell established an automated production process to more efficiently manufacture horseshoe nails than the conventional method of laborious hot forging by hand. Soon after the formation of the company in 1881, farriers made Capewell the leading brand of horseshoe nails in America. As its tradition has been for over 135 years, Capewell continues to improve the quality and selection of its products, the variety of sizes and services to its customers. That's why Capewell remains the leading brand in horseshoe nails today. Capewell. For farriers since 1881.

### St. Croix Forge Horseshoes

---

The founders of St. Croix Forge set out to build a better horseshoe to make the farriers job more efficient. Shortly after the introduction of their horseshoes, farriers made St. Croix Forge the most widely used horseshoe brand in North America.

St. Croix Forge is today known for products that are easy to use, which help make the farrier's job easier and horses' athletic work more efficient.

Whether a simple shoe for a trail horse, clipped shoes for a jumper, or aluminum racing plates, SCF workmanship and forging excellence is appreciated by everyone who uses them.

### Mustad

---

From its pre-industrial Norwegian origins in 1832 and its early days through 1860 in the small village of Gjøvik, Mustad grew to become one of the leading suppliers of small metal products. In particular items made from steel wire, such as horseshoe nails, propelled Mustad in to the horse/hoofcare industry. Mustad developed advanced machinery for the automatic production of horseshoe nails. This technological breakthrough led to a rapid expansion of business largely through exports to various European countries. Today Mustad Branded products range from horseshoe nails, horseshoes and farrier tools to therapeutic shoes for horses. Mustad is active in nearly 100 countries worldwide, offering some of the highest quality products on the market for over 189 years.

### Heller Rasps

---

In the Mid-1800's an enterprising German immigrant named Elias Heller started his own small shop in Newark, New Jersey. By the mid-1860's, three of Elias's sons - Elias George, Peter, and Lewis - entered the business and worked to build upon what their father started. Under their leadership, and for the next three generations, Heller became a leader among tool manufacturers by automating production of high quality files and rasps.

In 1955, Simonds acquired Heller Bros. For the next fifty years they produced rasps before deciding to focus on other categories of tools and leave the rasp business in 2006. That year, Mustad acquired the rasp assets and organized the products around the origins of the Heller Brand, building on Simonds contributions. Today, farriers continue to count on the strong heritage and tradition of quality rasps such as the Legend, Red Tang, Blackmaster, Big Hoof, Gr8at Rasps and the eXceL series which are manufactured under the Heller International brand.

### Delta

---

Delta started as a family operation in 1984 and consisted of horseshoe nails, horseshoes, and tools. All Delta products are designed with farriers to meet the highest standards in a demanding industry. Over the years, Delta has expanded to build a strong brand presence in Hoof Power Supplements and Delta Hoof Boots. Delta has a history of working closely with farriers, which has led the brand to manufacture a wide variety of solid products.



# TABLE OF CONTENTS

## NEW PRODUCT SECTION

Nails, Horseshoes, Rasps, Aprons and Supportive Hoof Solutions ..... 5 - 9

## HORSESHOES - St. Croix Forge, Delta, Equine & Mustad

St. Croix Forge Steel Shoes ..... 10 - 22  
 St. Croix Forge Aluminum Shoes ..... 23 - 24  
 Mustad Steel & Alum Shoes ..... 25 - 33  
 Delta Shoes ..... 34 - 35  
 Double S Shoes ..... 36 - 37  
 Speciality Shoes ..... 38  
 St. Croix Forge Racing Plates ..... 39 - 53

## HORSENAILS

Capewell ..... 54 - 57  
 Mustad ..... 58 - 64  
 Delta ..... 65 - 67  
 Cooper ..... 67

## HOOF RASPS

Heller Rasps / Sneaker / Bellota ..... 68 - 72

## TRACTION

Studs ..... 73 - 75  
 Accesories ..... 76

## TOOLS

Grant Moon Farrier Tool Range..... 77 - 81  
 Mustad Premium Tools ..... 82 - 83  
 Mustad Tools ..... 84 - 91  
 Edge Tools..... 92  
 Double S Tools & Knifes ..... 93 - 96  
 Jim Blurton Tools ..... 97 - 98  
 GE Tools ..... 99

## ANVILS/APRONS

TFS Anvils ..... 100 - 105  
 Hoof Stands / Aprons..... 106 - 107  
 Tool Box ..... 108

## HOOF CARE/HOOF TREATMENT/NUTRITION

ComfortMix ..... 110 - 111  
 No-Snow Pads..... 112  
 No-Shock Pads ..... 113  
 Castle Pads ..... 113 - 115  
 Myron McLane / EZ Strider / Shock Tammer Pads..... 115  
 Farriers Pride Pads/ Luwex Products ..... 116  
 Thrush Buster / Tuff Stuff / Hoof Shield / Hoof Marvel..... 117  
 Delta Hoof Boots ..... 118  
 Delta Hoof Power / Magic Cushion / Sole Pack ..... 119



# PRODUCT SECTION BY MUSTAD HOOF CARE CENTER

## NEW FORGED NAIL FOR THE NORTH AMERICAN FARRIER



CH6 CH5 SB5

### Mustad Power Forged Nail Features

- Drives high and comes out where you want it
- Deep waffle stamp plus M at the head
- Forged with the highest grade steel
- Better clinching than competing brands
- Does not shear like competing brands
- Precise points



## MUSTAD ENDURA NAILS

Concave



MX



ESL Pitch



### MUSTAD ENDURA

- Endura coating provides up to 30% additional strength, so you are able use a slimmer nail when needed
- Endura coating prevents rust, leaving clean hooves without oxidation marks
- Improves nail driving and reduces hoof wall damage
- Enhanced durability and stronger clinches



Concave		MX		ESL Pitch	
Size	Length	Size	Length	Size	Length
3	50.5	50	50	3	47.5
4	53.5	55	53	4	51
5	56.5	60	54.5	5	54

\*Nails length in mm by sizes



### MUSTAD COPPER NAILS

- Copper coating prevents rust which eliminates the discoloration around the nail holes
- Copper coating thickness exceeds industry standards
- Available in the most popular nail styles to fit a variety of shoes



Concave		MX		ESL		Combo	
Size	Length	Size	Length	Size	Length	Size	Length
3	50.5	50	50	3	47	5	59.5
4	53.5	55	53	4	51		
5	56.5	60	54.5	5	54		

\*Nails length in mm by sizes

### Capewell Endura SB 5



Capewell quality with the added benefits of Endura coating!

- Endura coating provides up to 30% additional strength, so you are able use a slimmer nail when needed
- Endura coating prevents rust, leaving clean hooves without oxidation marks
- Improves nail driving and reduces hoof wall damage
- Enhanced durability and stronger clinches

### MUSTAD SLIDER 4.5



The Mustad Slider 4.5 nail brings performance and efficiency to the Reining Circuit.

- Flat head
- Made to fit flush with plates
- Reduces the need to rasp nail heads
- Secures a locking fit with most sliding plates
- Saves time

### DELTA COPPER NAILS

YOUR FAVORITE DELTA NAILS  
NOW AVAILABLE IN COPPER

City Head Slim

Combo Slim

E Slim Blade

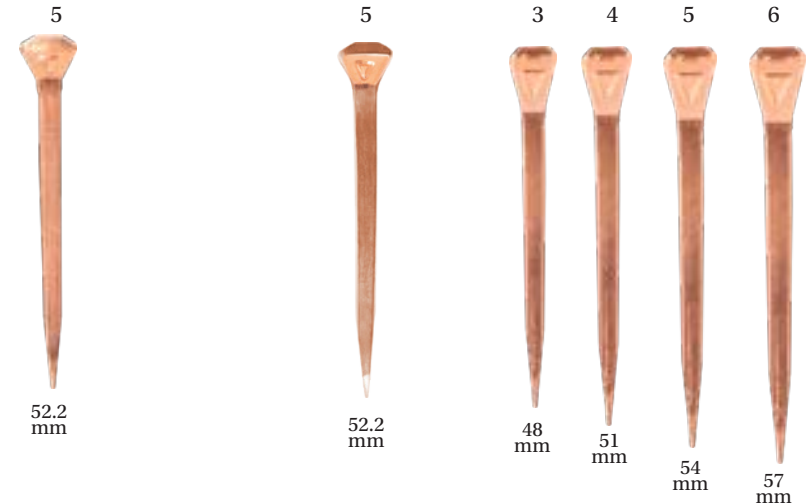



St. Croix Forge CrossOver



- Designed with a variable pitch
- Recommended nails: SB 6, CH 5, Concave 3, MX45
- Packaging: Box of 10 pairs
- Longer narrower shape is well suited for a variety of horse breeds
- This 8mm shoe features a deep fullering

**Options Available**

Side Clips	Front
Sizes	1-4
Toe Clip	Front
Sizes	1-4
Unclipped	Front
Sizes	0-4
Quarter	
Clipped	Hind
Size	0-4

Mustad Aluminum Therapeutic Shoes



**EggBar**  
Sizes: 00-4



**Straight Bar**  
Sizes: 00-4



**HeartBar**  
Sizes: 00-4



**Roller Front Bar**  
Sizes: 00-4



COMFORTMIX



**HOOF PAD SOFT**



**SUPER BOND**



**HOOF PAD**



**SILICONE**



**HOOF PAD ZNO**



**HOOF REPAIR BLACK**



**Comfort 200cc  
Dispenser**



**Mixing Tips**



**ST. CROIX FORGE**

**FORGING EXCELLENCE**

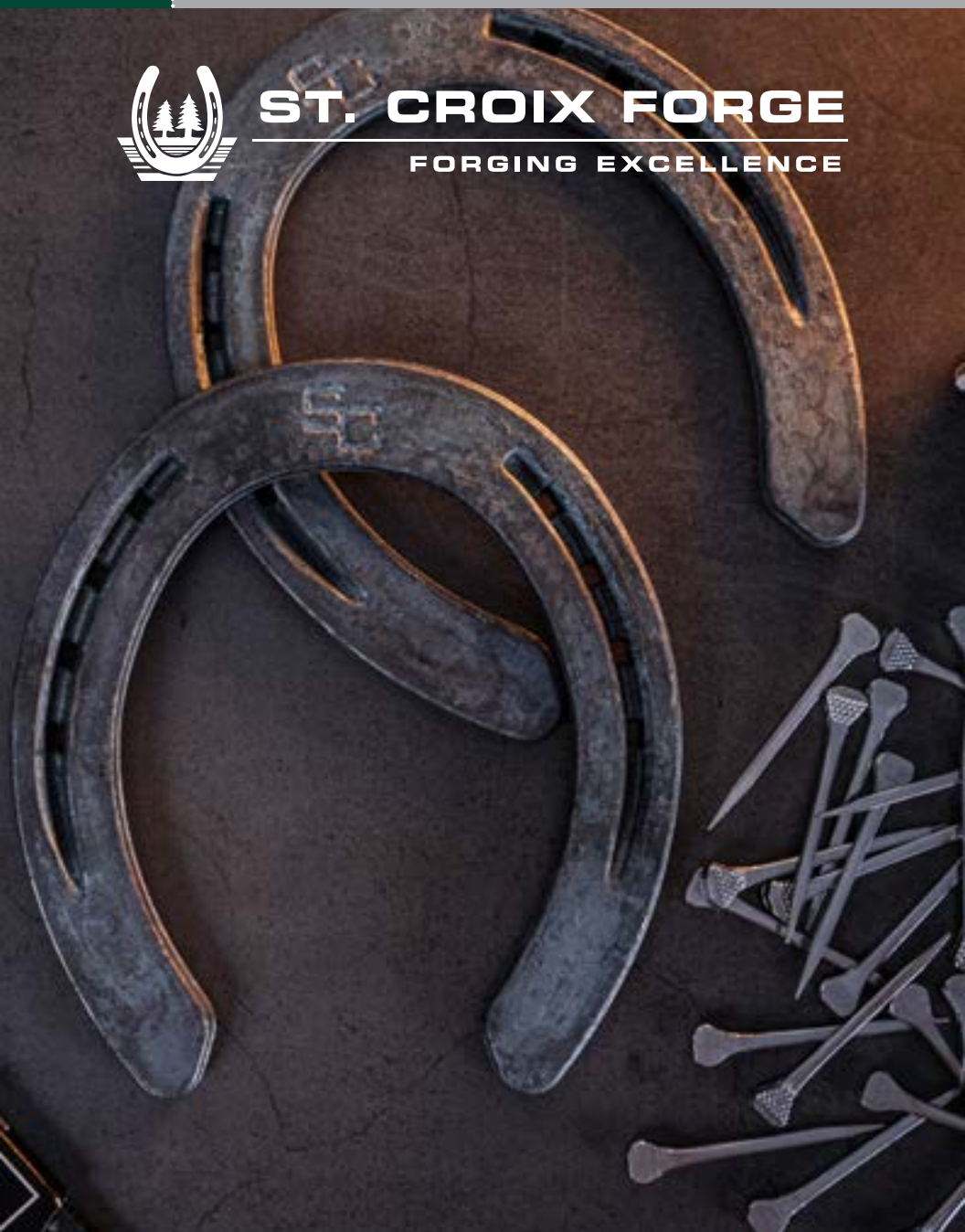

### CrossOver

The CrossOver features the latest in horseshoe technology, Variable Pitched Nails (VPN). What that means is that the nail holes have more pitch in the toe and become straighter towards the heel, following the natural angle of the hoof.



- Designed with a variable pitch
- Recommended nails: SB 6, CH 5, Concave 3, MX45
- Packaging: Box of 10 pairs
- Longer narrower shape is well suited for a variety of horse breeds
- This 8mm shoe features a deep fullering

#### Options Available

Side Clips	Front
Sizes	1-4
Toe Clip	Front
Sizes	1-4
Unclipped	Front
Sizes	0-4
Quarter	
Clipped	Hind
Size	0-4

## Eventer - Front & Hind

The Eventer design provides the protection and support of a wide web shoe with the breakover, and traction of a rim shoe. The heel shape allows for a tight fit while still providing enough material for support and studs when required. The front and hind shapes typically require minimal shaping.



- Rolled-toe shoe
- Concave hoof surface
- Graduated thickness
- Suggested nail:  
Size 000 / 4.5 RN  
Size 00-3 / CH 5  
Size 4 / CH 6

### Options Available

Side Clips	Front & Hind
Sizes	000-4
Unclipped	Front & Hind
Sizes	000-4
Toe Clip	Front
Size	2
Weight	Regular
Pkg.	20pr/box
	3-4; 10pr/box
Clip Pkg.	10pr/box

## Xtra

That extra something, forged into a shoe. Extra width, extra protection, perfect for "in-between" sized feet.

- Extra wide, extra protection
- Perfect for in-between sized hooves
- Suggested nail size: CH 5
- The generic pattern allows the shoe to easily shape for front or hind feet.

### Options Available

Unclipped	Front & Hind
Sizes	00-5
Toe Clip	Front & Hind
Sizes	0-5
Weight	Regular
Pkg.	00-2; 20pr/box
	3-5; 10pr/box



## Eventer PLUS - Front & Hind

Wider web provides added support, full crease contributes to improved traction. Symmetrical front, left and right hind patterns.

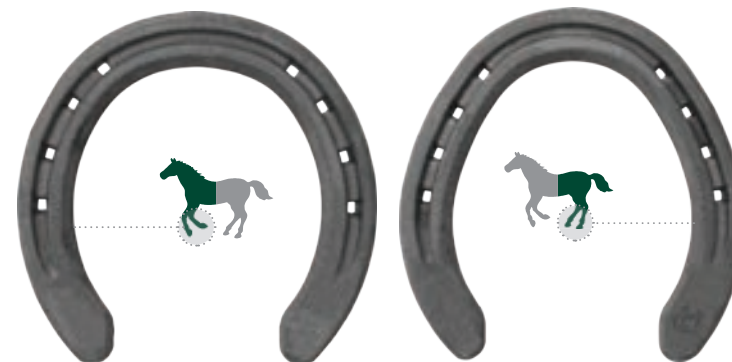

### Options Available

Side Clips	Front & Hind
Sizes	0-4
Unclipped	Front & Hind
Sizes	0-3
Weight	Regular
Pkg.	0-1; 20pr/box
Clip Pkg.	2-4; 10pr/box
	10pr/box

- For thicker hoof walls
- Lateral hind branches slightly longer and wider
- Suggested nail:  
Size 0-1 / CH 5  
Size 2-4 / CH 6

## PLUS Shoe Improvements:

- Left and right hind pattern with support fit heels
- Lateral hind branches slightly longer and wider
- Finished boxed heels on hoof surface
- Sole pressure relief
- Wider web and thickness appropriate to the size of the shoe
- Improved crease for perfect nail locking
- Front and Hind shoes come with side clips only



Clipped shoes

Finished boxed heels

For a wide selection of Nails engineered specifically for St. Croix Forge shoes see pages 53-65.

### SureFit

These shoes are based on the popular line of Lite shoes, in a front and hind pattern with a **V-crease**.

- V-crease for better nail positioning
- Web grows with the size of the shoe
- Available with side clips
- Suggested nail size: CH 5
- Reduce time on the anvil
- Sole pressure relief
- Finished heels
- Suggested nail size: CH 5

#### Options Available

Unclipped	Front & Hind
Sizes	000-1
Side Clips	Hind
Sizes	00-2
Weight	Lite
Pkg.	20pr/box
Clip Pkg.	10pr/box

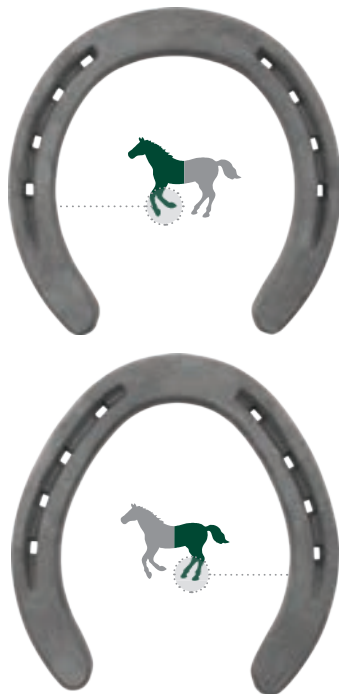

### SureFit Rim

Same features and benefits as our other Surefit shoes but the Rim allows for maximum traction. Upright edges minimize slippage in turns while maximizing push off and upright full heels allow for maximum support.

- V-crease for better nail positioning
- Rim allows for maximum traction
- Suggested nail size: Capewell - CH 5
- Upright edges minimize slippage while maximizing push off
- Upright full heels allow for maximum support

#### Options Available

Front & Hind	
Sizes	00-1
Weight	Lite
Pkg.	20pr/box



For a wide selection of Nails engineered specifically for St. Croix Forge shoes see pages 53-65.

### EZ - Front & Hind

The EZ is a front and hind shaped wide web shoe providing additional support for the hoof and limb. The wider section of steel and optimal shape allow for easy modification.

- Wider web provides great hoof protection
- Suggested nail: Size 00-3 / CH 5  
Size 4 / CH 6

#### Options Available

Side Clips	Front & Hind
Sizes	00-4
Unclipped	Front & Hind
Sizes	00-4
Toe Clip	Front
Sizes	1-3
Weight	Regular
Pkg.	00-2; 20pr/box 3-4; 10pr/box
Clip Pkg.	10pr/box



### EZ PLUS Front & Hind

EZ Plus offers a wider web for additional support and boxed heels to save time. The fronts are symmetrical, while the hinds come in a left and right pattern with added length in the outside branch. Using a deep "V" crease to secure the nail, this shoe is punched for an SB5 nail.

- V-crease
- Safer locking of nail head into shoe
- Better nail positioning
- Extreme durability
- Excellent support
- Added protection
- Heavier than a standard shoe

#### Options Available

Unclipped	Front & Hind
Sizes	0-1; 20pr/box 2-3; 10pr/box
Side Clips	Front & hind
Sizes	0-2; 10pr/box
Weight	Regular





## Concorde - Front & Hind

The Steel Concorde was designed with the same features that have made the Eventers one of the most popular shoes, but in a lighter version. It is a good alternative for those who look for a stronger and more durable option to the aluminum shoes.

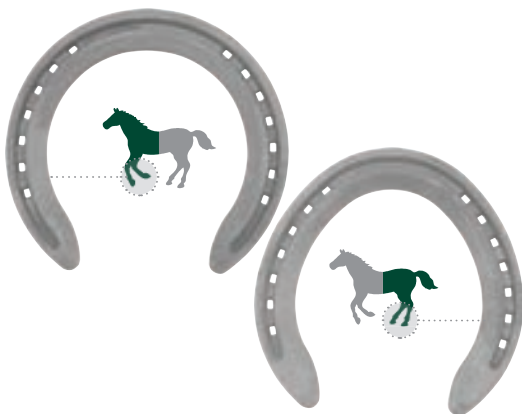

Toe Clip

### Options Available

Unclipped Front	3-8; 10pr/box
Unclipped Hind	3-7; 10pr/box
Toe clip hind	3-6; 10pr/box
Weight	Lite

## Polo Front

Traction, turns, and enhanced breakover, carefully engineered.

- Signature higher inside rim
- Also available in a compromised pattern (regular).
- Suggested nail size: SB 5  
Original Polo: 00-1  
00 / RN 4.5  
0-1 / PS 5

### Options Available

Front	00-1
Regular	0-1
Pkg.	20pr/box



For a wide selection of Nails engineered specifically for St. Croix Forge shoes see pages 53-65.

## Plain

This shoe became an industry standard for a solid everyday application. The generic pattern allows for easy front or hind shaping while the dimensions offer excellent durability and reset options.

This is America's basic flat creased horseshoe, designed for versatile use wherever you shoe.



### Options Available

Sizes	000-3
Weight	Reg or Lite
Pkg.	20pr/box 3; 10pr/box

- Designed for versatile use
- Suggested nail size: CH 5

## Ultra Lite Rim



### Options Available

Sizes	000-2
Pkg.	20pr/box

Provides exceptional traction in a super light weight all purpose shoe. Built on the successful Plain Lite Rim shoe and nail pattern, this reduced weight and increased traction shoe is ideal when shoe weight is a primary concern. The generic shape is easy to modify and features a crease from heel to heel.

- Thin as a training plate
- Forged for strength
- Full crease & rolled toe
- Suggested nail:  
Size: 000-00 / RN 4.5  
Size: 0-2 / RN 5
- Available in toe clip (000-0)

## Lite V-Crease

Take the proven design of the Plain and make it slightly thinner to reduce some weight, and you have the Lite V-crease.

The generic pattern is easily shaped into a front or hind. This shoe features a V-crease to improve nail-to-shoe contact for a more secure fit.



- V-crease design for optimized nail fit and pitch
- Sole relief
- Full crease

- Punched for CH5
- Generic pattern
- Sizes: 000-4

## Lite Rim V-Crease

Provides exceptional traction in a lightweight all-purpose shoe. Built on the successful St. Croix Forge plain shoe and nail pattern, this reduced weight and increased traction shoe is a favorite among western sport horses. Features a rolled toe which eases breakover.

- V-crease design for optimized nail fit and pitch
- Sole relief
- Full crease
- Sizes: 000-2



## Rim V-Crease

This Rim shoe has a V-crease from heel to heel with softened outer edges and a slight rolled toe. The V-crease greatly improves nail-to-shoe contact for a more secure fit. It is an excellent choice for traction, safety and durability. Featuring a generic pattern, the shoe is easily shaped to a front or hind foot.



- V-crease design for optimized nail fit and pitch
- Sole relief
- Full crease
- Sizes: 000-2

For a wide selection of Nails engineered specifically for St. Croix Forge shoes see pages 53-65.



## Heeled

This heeled shoe is based on our generic shaped Plain model. The addition of the heels provides added traction in a variety of different terrain.

- Angled heel caulk
- Perfect for rough ground
- Suggested nail size: CH 5

### Options Available

Sizes	0-2 Reg
Sizes	000-2 Lite
Weight	Reg or Lite
Pkg.	000-00; 20pr/box 0-3; 10pr/box

## Pony

The pony shoe is designed for our smallest equine customers. The generic shape is ideal for ponies and easily modified into fronts or hinds.

- Smaller version of our "Plain" shoe
- Drop-forged for strength
- Suggested nail size: RN 4.5

### Options Available

Sizes	0-1
Weight	Lite
Pkg.	40pr/box



## Toe & Heel

The Toe and Heel model provides excellent traction for rough terrain. Specifically designed heel caulks and toe grab delivers grip, and protects the shoe from excessive wear.

- Maximum traction
- Rounded toe grab
- Suggested nail size: CH 5

### Options Available

Sizes	000-4 Reg
Sizes	000-2 Lite
Weighs	Reg or Lite
Pkg.	20pr/box 0-3; 10pr/box

## Mule

Our Mule shoe has been designed to minimize shaping and provides excellent durability.

- Improved shape
- Added traction of heels
- Suggested nail size: CH 5

### Options Available

Plain	000-0
Heel	00-0
Weight	Regular
Pkg.	20pr/box



For a wide selection of Nails engineered specifically for St. Croix Forge shoes see pages 53-65.

## Advantage Steel

The Advantage offers excellent traction and added support. Available in front and hind patterns.

- Easy break-over in any direction and well-designed bold toe
- V-Crease for optimum nail seating and pitch
- Optimal heel support through wide heel design
- Concave inner web on ground surface
- Available clipped or unclipped

### Options Available

Side Clips	Front & Hind
Sizes	00-2
Unclipped	Front & Hind
Sizes	00-2
Pkg.	20pr/box



For a wide selection of Nails engineered specifically for St. Croix Forge shoes see pages 53-65.

## Advantage Aluminum

The Advantage Aluminum is designed to provide an optimal balance between support and weight for a variety of sport horses. The front shape typically requires minimal shaping and the steel wear insert keep the toe from wearing out prematurely. The profile design promotes breakover while providing ample traction.

- Easy break-over in any direction and well-designed bold toe
- V-Crease for optimum nail seating and pitch
- Optimal heel support through wide heel design
- Concave inner web on ground surface
- Available clipped or unclipped

### Options Available

Side Clips	Front
Sizes	00-3
Unclipped	Front
Sizes	00-1
3Deg Wed	Front
Sizes	00-1
	00-2; 20pr/box
Pkg.	3; 20pr/box

- 70 % lighter
- Patterned after steel EZ
- Forged-in wear inserts
- State-of-the-art side clips
- Suggested nail size: 5 CH

### Options Available

Side Clips	Front
Sizes	00-4
Pkg.	10pr/box



Clipped Shoes

## Advantage in Movement



## Front - Aluminum EZ

Patterned after our front pattern steel EZ, its wide, full profile offers great support with forged in wear inserts, state-of-the-art side clips and the lightness of aluminum.

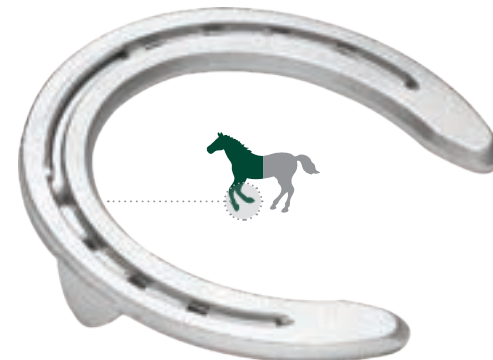

## Front & Hind - Aluminum Eventer

- **70 % lighter**
- **Patterned after steel eventer**
- **Forged-in wear inserts**
- **State-of-the-art side clips**
- **Lightness of aluminum**
- **Suggested nail size: 5 CH**

The St. Croix Forge Eventer Aluminum is a lightweight version of the popular steel version, saving an estimated 70% in weight. Featuring a deep crease through the toe, it provides traction while the rolled toe helps to reduce leverage. A steel insert is embedded at the toe to prevent excessive wear.

### Options Available

Side Clips	Front & Hind
Front Sizes	000-3
Hind Sizes	000-2
Unclipped	Front & Hind
Front Sizes	000-2
Hind Sizes	00-2
Pkg.	10pr/box



## Front - Aluminum Eventer PLUS

- **70 % lighter**
- **State-of-the-art side clips**
- **Suggested nail: Size 0-4 / CH 5**

Same great features as the Steel Eventer PLUS, state-of-the-art side clips with the lightness of aluminum.

### Options Available

Unclipped	Front
Sizes	0-2
Side Clips	Front
Sizes	0-4
Pkg.	10pr/box



Clipped shoes

For a wide selection of Nails engineered specifically for St. Croix Forge shoes see pages 53-65.



Mustad horseshoes are designed and crafted according to two key principles: the best shoes for the horse and optimal ease of application for the farrier. For this reason, our range of products is very broad. Mustad horseshoes can be applied to suit practically all possible circumstances, from the physical condition of the horse to any local requirements. We work in a state-of-the-art production environment, ensuring that you can always rely on the precision and consistency of our steel horseshoes.



# EQUI-LIBRIUM AIR

## The next level of sport shoes

The Equi-Librium™ AIR is available for front and hind feet: scientific studies prove that Equi-Librium™ AIR eases the breakover, thus decreasing the peak load and improving coordination:

- Newly designed front model, 15% lighter than standard Equi-Librium™
- Distinctive Equi-Librium™ rolled toe, more pronounced in the hind model
- Concave section through the toe providing extra grip
- Additional width in the heels for optimal support
- Clips in front shoe are positioned between the 1st and 2nd nail holes providing stability



Science-based design: the Equi-Librium™ rounded toe eases breakover. Anatomical shape and section-to-size design provides a proper fit, and saves farrier's time on the job.

### Options Available

Front Clips: 00, 0, 1, 2, 3, 4

Hind Clips: 00, 0, 1, 2, 3, 4

## Equi-Librium Steel Front

Designed at a leading Netherlands University, Olympic Champions and Endurance Performers World Wide have confirmed the success of the science driven design of the Mustad Equi-Librium sport horseshoe.

- Lateral branch is slightly longer
- Extra wide toe area is forged with a 2-dimensional convex curve allowing fluent breakover in any direction
- Center mass matches the Center of Pressure during mid-stance of the horse creating a perfectly balanced hoof
- Inside edge of the ground surface's concave section is balanced to reduce weight and mud build up
- Concave section and crease do not run through the heels to improve support during landing
- Full heels allow forging a variety of individualized alternatives to the heel area
- Beveled Edges, Sole Relief, and Flush Clips are all standard
- V-crease for better nail positioning and seating of Mustad Nails



### Options Available

Side Clips	Front
Sizes	00-4
Unclipped	Front
Sizes	00-3
Pkg	10pr/box
Packaged L & R	/ per pair

- Suggested nail size:  
00-00 / ESL 3 / LiBero ARC 3  
0-2 / ESL 4 / LiBero ARC 4  
3-4 / ESL 5 / LiBero ARC 5



### LiBero

The Mustad LiBero® is a 3/4 fullered all-round horseshoe. We like to think of it as an upgrade on our base range making it suitable for most leisure and sport purposes with a wide variety of sizes and sections.

# LiBero

#### INNOVATIVE FEATURES

- Section-To-Size: dimensions change according to shoe size
- Follows the asymmetrical foot shape
- Front and hind have definite left and right shapes
- Slope heels for front shoes, upright heels for hind shoes
- Edges are rounded or boxed
- Suggested nail model: LiBero ARC, Concave, EXL



Options Available

Front Side Clips (Blunt Toe)	Front Quarter Clips (Round Toe)	Front Toe Clip	Hind Side Clips
22x10 2, 3	20x8 00, 0	20x8 0	20x8 00, 0, 1
	22x8 0, 1, 2, 3	22x8 0, 1, 2, 3, 4	22x8 0, 1, 2, 3, 4
	25x8 3, 4, 5	25x8 3, 4, 5	25x8 2, 3, 4, 5
		22x10 2, 3, 4	22x10 2, 3, 4
		25x10 4, 5, 6	25x10 4, 5, 6

### LiBero Equi-Librium

The extreme versatility of LiBero is now combined with the scientifically proven benefits of Equi-Librium, to provide more options to both the farrier and the horse.

- Great fit with all Mustad premium E-head nails
- Front side clips positioned between the 2nd and 3rd nail holes
- Equi-Librium rolled toe and quarters to enhance smooth breakover where the horse needs it
- Long-lasting durability on all terrains
- Sole relief to minimize sole pressure
- Wide heels for more support
- Optimal nail holes positioning
- Comes in left and right pattern following the asymmetrical foot shape

# LiBero Equi-Librium



Options Available

Front Quarter Clips
22x8 000
22x8 00
22x8 0
22x8 1
22x8 2
22x8 3
22x8 4

For a wide selection of Nails engineered specifically for Mustad shoes see pages 53-65.



### DynaMic

The Dynamic shoe is the result of years of feedback from farriers in Europe. Innovation and production objectives were to create a shoe that needs less work to shape and forge for this style of horseshoeing.

- Left and right hind pattern
- Bumped toe
- Built in sole relief
- Punched for E-head nails
- Additional support at the heels
- More narrow in the branches
- Clips positioned between 1st and 2nd nail holes

## DynaMic Horseshoes

U.S.A SIZE	DynaMic SIZE (2 sizes larger)
1	3
2	4
3	5
4	6



Front Side Clips

19x8	1,2
22x8	3,4,5,6

Hind Side Clips

19x8	1,2,3
22x8	3,4,5,6
19x10	3
22x10	4,5,6,7

### Equi-Librium Aluminum Front

When a fraction of a second is the difference between a win or a loss, the Equi-Librium Aluminum makes the difference. Sizes 000-4

- 65% lighter than steel shoes
- Holds up as well as steel
- Shoes come with quarter clips
- Suggested nail size:  
000-00 / ESL 3 / LiBero ARC 3  
0-2 / ESL 4 / LiBero ARC 4  
3-4 / ESL 5 / LiBero ARC 5



### Aluminum Outer Rim - Hind

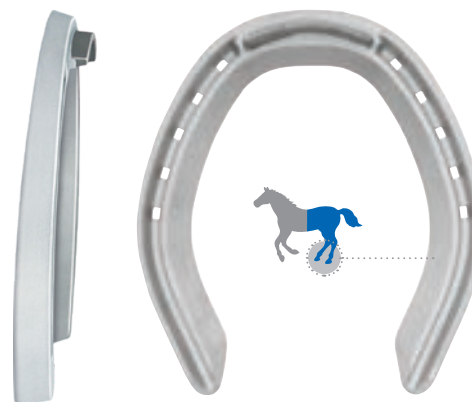

Blunt toe shape for easier breakover. Raised steel toe insert for increased traction.

- Blunt toe shape for easier breakover
- Raised toe insert for increased traction
- Suggested nail size:  
RN 4.5 or RN 5

#### Options Available

Sizes	0-4
Pkg.	15pr/box

For a wide selection of Nails engineered specifically for Mustad shoes see pages 53-65.



**THERAPEUTIC SOLUTIONS** by

**MUSTAD**

- Mustad Equi-Librium mechanics for ease of breakover
- Dimensions to offer support without being obtrusive
- North American style nail hole positioning (nails have been moved out of the toe mechanics)
- Sole Relief
- Crease and Nail hole design to provide precision fit when "setting" the suggested nail
- Deep Crease
- Center of shoe mark in toe to help achieve the desired shoe placement



EggBar  
Sizes: 00-4



Straight Bar  
Sizes: 00-4



HeartBar  
Sizes: 00-4



Roller Front Bar  
Sizes: 00-3

Egg Bar

Drop forged with no welds. This shoe features a true crease, precise nail holes, and is easy to fit shape.

**Options Available**

Sizes	00-3 Unclipped
Sizes	00-3 Side Clips
Pkg.	1 Opr/box

- Drop-forged with no welds
- Precise nail holes
- Available in quarter clips or unclipped
- Suggested nail size: CH 5



For a wide selection of Nails engineered specifically for Mustad shoes see pages 53-65.

## TS7 & TS8 - Challenger

Truer fit, longer wear, and greater performance in both front and hind patterns. The full toe design allows the shoe to last longer and the balanced shape means less time at the anvil. The Challenger also features sole relief while the nail holes are perfect for thin walled hooves. The TS8 model is even thicker and slightly wider for greater support, and protection of the hoof.



- Turned steel shoe made in Europe
- Accurate shape for true fit
- Full toe for longer wear
- Built-in sole relief for less time on the anvil
- Nail hole placement perfect for thin walled hooves
- Suggested nail size: CH 5

### Options Available TS7

Sizing	000 to 0 18x7mm
	1 18.5x7mm
	2 18.5x7mm
Side Clips	Hind
Unclipped	Front & Hind
Pkg.	10pr/box

### Options Available TS8

Sizing	00 to 0 19x8 MM
	1 20x8 MM
	2 21x8 MM
	3 22x8 MM
	4 23x8 MM
Side Clips	Front & Hind
Unclipped	Front & Hind
Pkg.	10pr/box

## Regular Keg Shoes

Featuring a compromised pattern that is easily modified for a front or hind shape, the Delta Keg shoe is the perfect blend of American styling and European technology with a true crease and precise nail holes.

- Precision nail holes
- Suggested nail size: CH 5

### Options Available

Sizes	000-2
Pkg.	20pr/box



## Wide Web Keg Shoe

Offering the same features as the regular Delta Keg shoe, the Wide Web Keg shoe is built from wider stock to provide additional support and longevity.

- Built from wider stock to provide additional support
- Suggested nail size: CH 5

### Options Available

Sizes	00-3
Pkg.	20pr/box



For a wide selection of Nails engineered specifically for Delta shoes see pages 53-65.

**Double S Slider**

The Double S Slider features a rocker toe, four nail holes and a great easy fit shape. Made in Italy.

- Rolled toe
- Easy fit shape
- Made in Italy
- Suggested nail size: PS 5 or RN 4.5



"S 7/8" Type - Slider  
for Cutting 10-13" Length



"S" Type Slider  
1 1/4" 10-13" Length



"SM" Type - Slider  
Futurity 1 1/4" 10-13" Length



"SN" Type - Slider  
Futurity 1" 10-13" Length



"SL" Type - Slider  
1" 10-13" Length

**QH8**



**QUARTER HORSE SHOE**

- Front and hind patterns
- 8mm
- Suggested nail: CH5

Quarter Horse Shoe available in 00-2

**Double S Aluminum Horseshoes**



**FFA**  
Size: 00-1



**3FWA**  
Size: 000-1



**ABR**  
Size: 00-1



**AWEB**  
Size: 000-1



**RWA**  
Size: 000-1



**RFA**  
Size: 000-1



**AWB**  
Size: 000-1



**AWHB**  
Size: 000-1



**2FWA**  
Size: 000-1

## Blurton Steel Bar Shoes Clipped

Manufactured using one piece of metal with no welds. Shoes all have pitched nail holes, countersunk position for stud holes, rolled toe, and are safed off at the heel. All styles are clipped.



### Jim Blurton Heart Bar

Designed to offer maximum support to the foot and coffin bone while offering the farrier a shoe that is superbly balanced and easy to fit.

Sizes 00-2 Pkg. 10pr/box

### Jim Blurton Straight Bar

This shoe offers support to the heel and frog spreading the weight evenly throughout the foot.

Sizes 00-2 Pkg. 10pr/box



CHAMPIONS  
RUN ON  
TRUST &  
TRADITION

**TOE GRAB**

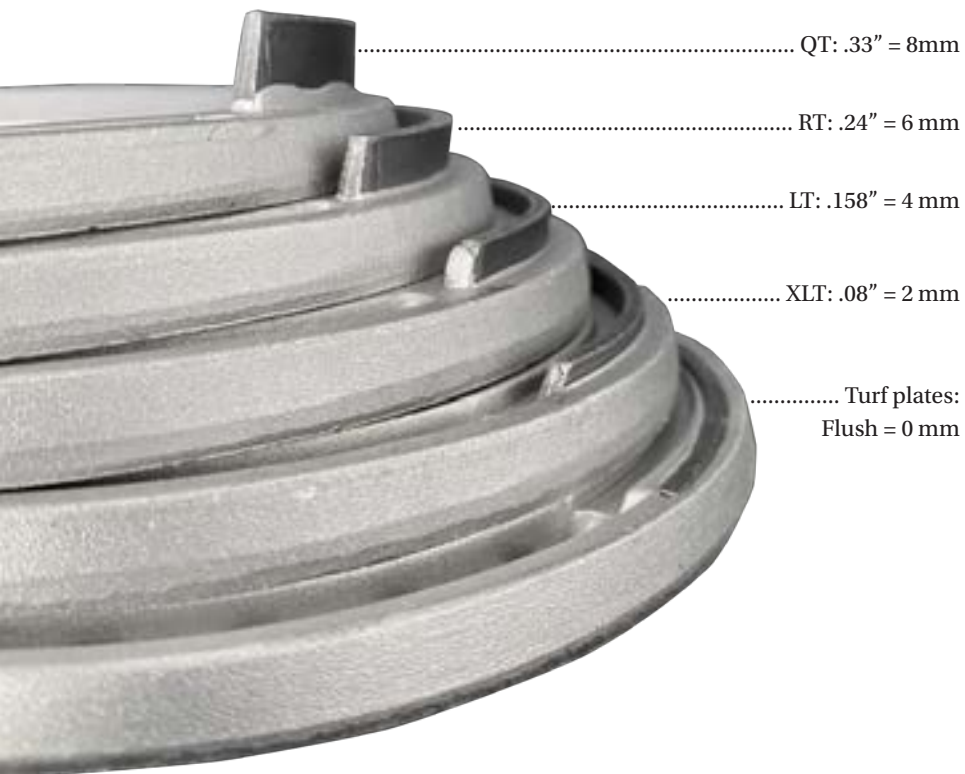

QT: .33" = 8mm

RT: .24" = 6 mm

LT: .158" = 4 mm

XLT: .08" = 2 mm

Turf plates:  
Flush = 0 mm

Shoe and toe grab regulations vary. Check Racetrack shoe policy to confirm which shoes or grabs are permitted.

Turf Plates - Front & Hind



The Turf Plates feature the traditional St. Croix Forge shape with a flush toe grab, ideal for events that don't allow protruding toe grabs. Meant for grass and training.

**Options Available**

**Sizes:** 3 - 8

**Pkg:** 2 pr/box  
5 box/case

**Recommended nail for this product**  
RN 3.5

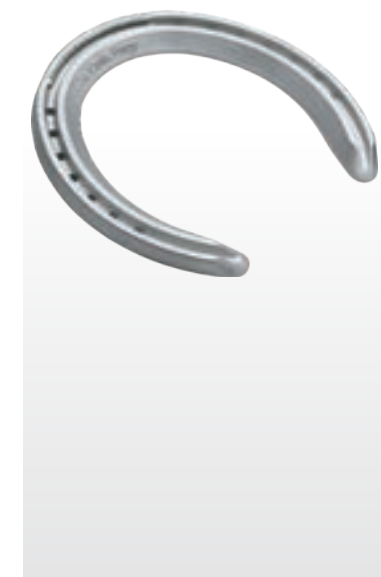
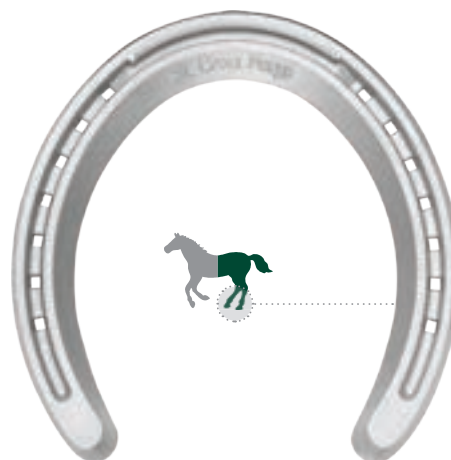

For a wide selection of Nails engineered specifically for St. Croix Forge shoes see pages 53-65.

## XLT - Front & Hind



The XLT features the traditional St. Croix Forge front & hind pattern with a .08" (2mm) toe grab. A popular choice for both dirt and turf racing.

**Options Available**

- Toe Clip:** Hind
- Side Clips:** Hind
- Unclipped:** Front & Hind
- Sizes:** 3 - 8
- Pkg:** 2 pr/box  
5 box/case

**Recommended nail  
for this product**  
RN 3.5



## Outer Rim

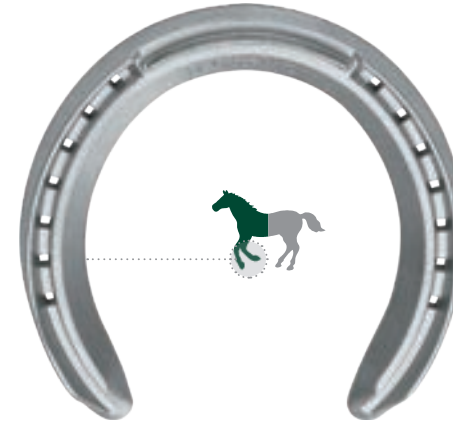

Outside rim and a .08" (2mm) raised toe grab for increased traction.

**Options Available**

- Sizes:** 3 - 8
- Pkg:** 2 pr/box  
5 box/case

**Recommended nail  
for this product**  
RN 3.5



## Low Toe - Front Pattern Only



This plate features a .158" (4mm) steel toe grab. Offers another traction option for dirt surfaces.

**Options Available**

- Sizes:** 3 - 8
- Pkg:** 2 pr/box  
5 box/case

**Recommended nail  
for this product**  
RN 3.5



For a wide selection of Nails engineered specifically for St. Croix Forge shoes see pages 53-65.

## Regular Toe Front & Hind



The Regular toe front & hind shoes feature a .24" (6mm) steel toe grab. A very popular choice for the hind shoe on dirt surfaces.

- Options Available**    **Sizes:**
- Unclipped Front:** 3 - 8
  - Unclipped Hind:** 3 - 8
  - Side Clips Hind:** 3 - 7
  - Toe Clip Hind:** 3 - 7
- Pkg:** 2 pr/box  
5 box/case

**Recommended nail  
for this product**  
RN 3.5

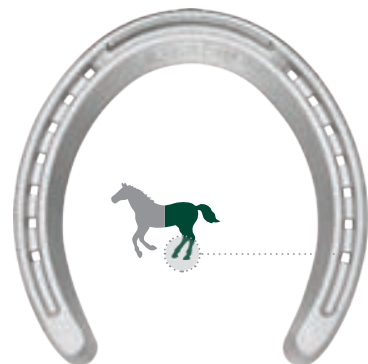

### Built-in Sole Relief



## Quarter Horse - Front & hind



The Quarter Horse model offers the ultimate traction. A front & hind racing plate with a .33" (8mm) steel toe grab. A dirt track option used behind many Quarter Horses and some Thoroughbreds.

- Options Available**
- Sizes:** 3 - 8
  - Pkg:** 2 pr/box  
5 box/case

Quarter Horse Hind 8mm

**Recommended nail  
for this product**  
RN 3.5

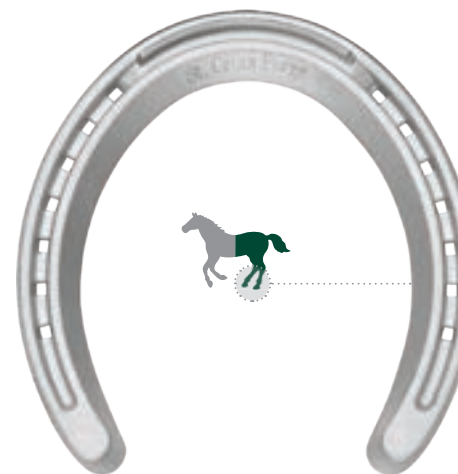

For a wide selection of Nails engineered specifically for St. Croix Forge shoes see pages 53-65.

## Quarter Horse Toe Block Heel

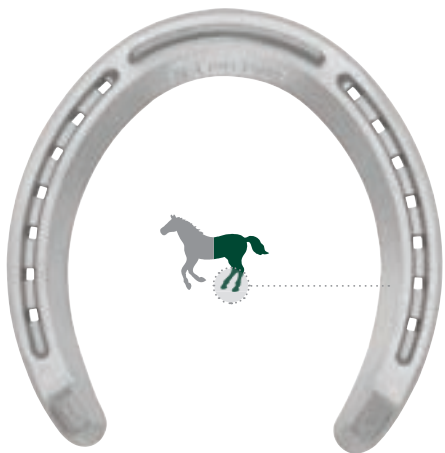

The Quarter Horse Toe Block hind plate features raised heel blocks to prevent running down and excessive heel grab. Has a .33" (8mm) steel toe grab.

**Options Available**

**Sizes:** 4 - 7  
**Pkg:** 2 pr/box  
5 box/case

**Recommended nail  
for this product**  
RN 3.5

## 2-Degree - Hind



Our 2-Degree wedge hind plate features a firm stable heel support for running horses, combined with a .24" (6 mm) steel toe grab. Also, assists in faster breakover.

**Options Available** **Sizes:**  
**Unclipped Hind:** 3 - 8  
**Toe Clip Hind:** 4 - 7  
**Side Clips Hind:** 3 - 7  
**Pkg:** 2 pr/box  
5 box/case

**Recommended nail  
for this product**  
RN 3.5



## Block Heel Regular Hind

The Block Heel Regular hind plate features raised heel blocks to prevent running down and excessive heel grab. Has a .24" (6mm) steel toe grab.

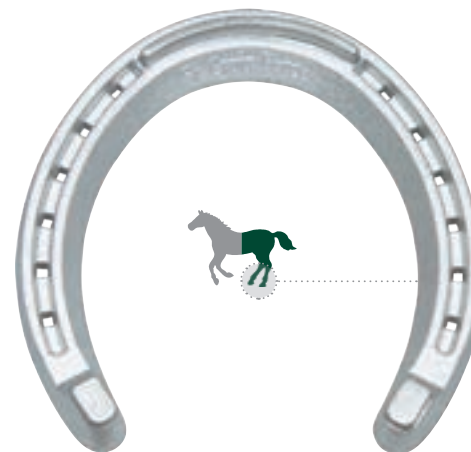

**Options Available**

**Sizes:** 3 - 8  
**Pkg:** 2 pr/box  
5 box/case

**Recommended nail  
for this product**  
RN 3.5



For a wide selection of Nails engineered specifically for St. Croix Forge shoes see pages 53-65.



## St. Croix Forge Racing Plates

Front

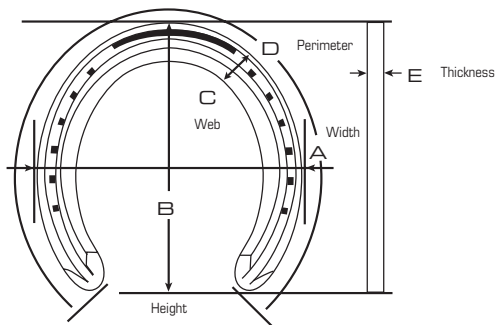

Hind

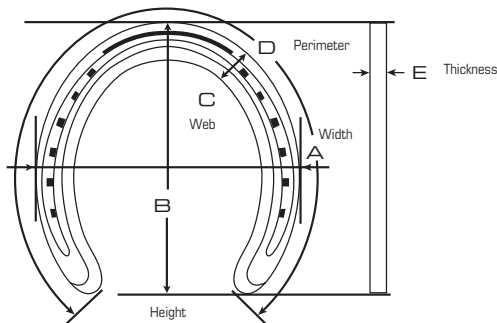

## Concorde Turf Plates Front & Hind



Concorde Turf Plates features a flush toe grab, where protruding toe grabs are not allowed. Frequently used for Turf Racing or in the early stages of training.

**Options Available**    **Sizes:**

**Unclipped Front:** 3 - 7

**Unclipped Hind:** 4 - 7

**Side Clips Hind:** 3 - 4

**Toe Clip Hind:** 3 - 7

**Pkg:** 2 pr/box

5 box/case

**Recommended nail  
for this product**  
RN 3.5

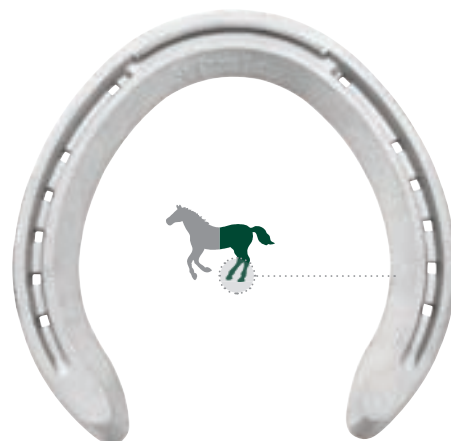

Toe Clip

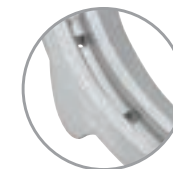

Side Clip

Size	A	B	C	D	E
3 Front	4 1/4	4 1/4	5/8	11 3/4	5/16
3 Hind	4 1/8	4 3/16	5/8	11	5/16
4 Front	4 7/16	4 15/32	11/16	12 1/4	5/16
4 Hind	4 5/16	4 13/32	23/32	11 3/4	5/16
5 Front	4 21/32	4 11/16	23/32	12 3/4	5/16
5 Hind	4 17/32	4 5/8	23/32	12 1/4	5/16
6 Front	4 7/8	4 15/16	3/4	13 1/4	5/16
6 Hind	4 3/4	4 13/16	3/4	12 3/4	5/16
7 Front	5 1/8	5 5/32	25/32	14	5/16
7 Hind	4 15/16	5 1/32	25/32	13 1/2	5/16
8 Front	5 11/32	5 3/8	13/16	14 1/2	5/16
8 Hind	5 3/16	5 1/4	13/16	14	5/16

Note: Dimensions A, B, C and D are listed to the nearest 1/8 inch.

Dimensions E is listed to the nearest 1/.16 inch

For a wide selection of Nails engineered specifically for St. Croix Forge shoes see pages 53-65.

## Concorde XLT Front & Hind



The Concorde shape with a .08" steel toe grab. A popular choice for both dirt and turf racing.

**Options Available**    **Sizes:**  
**Unclipped Front:** 3 - 8  
**Unclipped Hind:** 3 - 7  
**Toe Clip Hind:** 4 - 8  
**Pkg.** 2 pr/box  
       5 box/case

**Recommended nail  
for this product**  
 RN 3.5



## Concorde Regular Toe Front & Hind



The Concorde Regular toe model offers the ultimate traction. A front & hind racing plate with a .24" (6mm) steel toe grab. A popular choice on dirt surfaces for the hind shoe.

**Recommended nail  
for this product**  
 RN 3.5



**Options Available**    **Sizes:**  
**Unclipped Hind:** 4 - 8  
**Side Clips Hind:** 3 - 8  
**Toe Clip Hind:** 4 - 7  
**Pkg:** 2 pr/box  
       5 box/case

## Concorde 2-degree Regular Toe Hind European Thoroughbred



Our 2-Degree Wedge Hind plate features a firm stable heel support for running horses, combined with a .24" (6mm) steel toe grab. Assists in faster breakover.

**Options Available**    **Sizes:**  
**Unclipped Hind:** 3 - 8  
**Pkg:** 2 pr/box  
           5 box/case

**Recommended nail  
for this product**  
 RN 3.5

## Concorde Racing Plates

Front

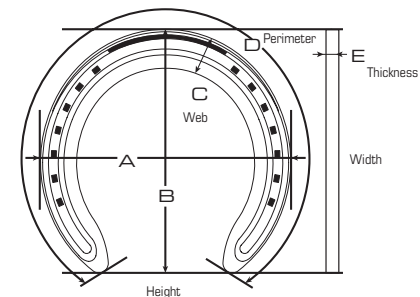

Hind

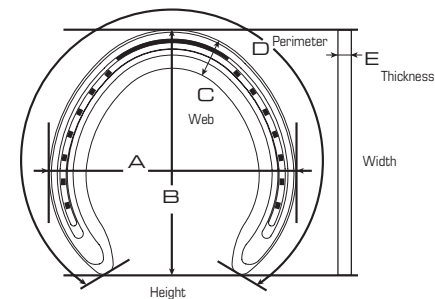

Size	A	B	C	D	E
2 Front	4 7/16	4 3/16	23/32	11 3/4	11 3/4
2 Hind	4 5/16	4 1/4	23/32	11 5/16	11 3/4
3 Front	4 5/8	4 5/16	23/32	12 1/4	12 1/4
3 Hind	4 15/32	4 7/16	23/32	11 7/8	11 3/4
4 Front	4 7/8	4 9/16	23/32	12 5/8	12 1/2
4 Hind	4 21/32	4 5/8	23/32	12 5/16	12 1/4
5 Front	5 1/16	4 11/16	3/4	13 1/16	13
5 Hind	4 7/8	4 13/16	3/4	12 13/16	12 3/4
6 Front	5 1/4	4 15/16	25/32	13 5/8	13 1/2
6 Hind	5 1/16	5	25/32	13 3/8	13 1/4
7 Front	5 1/4	5 1/16	13/16	14 3/16	14
7 Hind	5 1/4	5 3/16	13/16	13 3/4	13 3/4
8 Front	5 11/16	5 5/16	27/32	14 3/4	14 3/4
8 Hind	5 7/16	5 13/32	27/32	14 1/2	14 1/2

Note: Dimensions A, B, C and D are listed to the nearest 1/8 inch.  
 Dimensions E is listed to the nearest 1/.16 inch



The major technological inventions that have shaped the success of Mustad and Mustad products have been in the metal-mechanical field, particularly in items that can be made from steel wire - horseshoe nails being one such product. The result today is a horseshoe nail line of the highest quality standard in the industry. Each nail, whether Capewell, Mustad, Delta or Cooper, consists of a complexity of carefully computed tapers and angles with a sharp, beveled point for accurate placement and easy driving. Our two way cooperation with farriers from all over the world in combination with our advanced research and manufacturing know-how provide the farrier with the best possible horseshoe nail that money can buy.

### Regular Head

Used for larger shoes... farm, draft and show horses.  
Popular for resets.

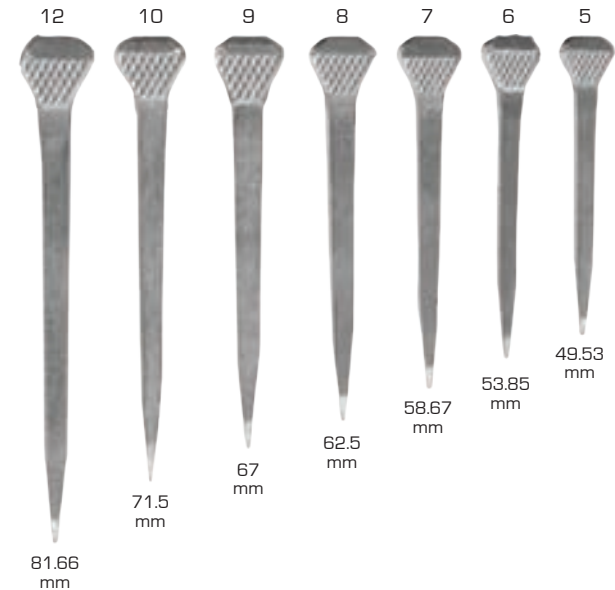

### City Head

General all purpose nail for use with saddle horses, working horses and ponies.

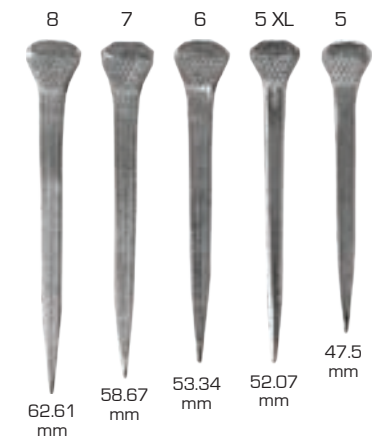

### Slim Blade

Drives with ease, with less hoof displacement.



### Endura Slim Blade 5



- Endura coating provides up to 30% additional strength, so you are able use a slimmer nail when needed
- Endura coating prevents rust, leaving clean hooves without oxidation marks
- Improves nail driving and reduces hoof wall damage
- Enhanced durability and stronger clinches

### Race

The leading, most widely used brand of Race Nails in the industry.

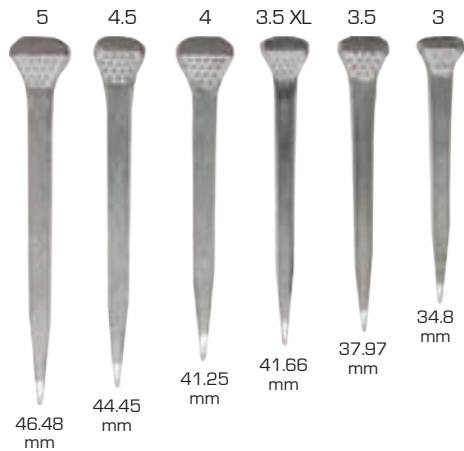

### Combo 5

For handmade and foreign made shoes.



### Platers Special

Has the length of a 5, the head of a 4.5 RN. Perfect for sliding plates!



### City Classic



**NEW FORGED NAIL FOR THE NORTH AMERICAN FARRIER**

- Drives high and comes out where you want it
- Deep waffle stamp plus M at the head
- Forged with the highest grade steel
- Better clinching than competing brands
- Precise points



Look for the new forged nail labels

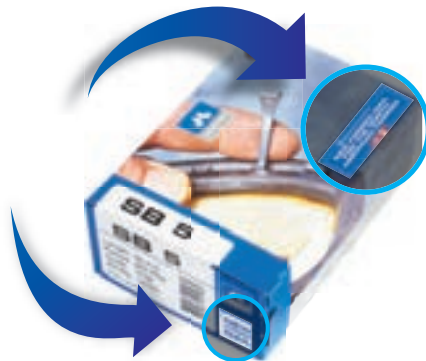

**MUSTAD ENDURA**

- Endura coating provides up to 30% additional strength, so you are able use a slimmer nail when needed
- Endura coating prevents rust, leaving clean hooves without oxidation marks
- Improves nail driving and reduces hoof wall damage
- Enhanced durability and stronger clinches



Concave		MX		ESL Pitch	
Size	Length	Size	Length	Size	Length
3	50.5	50	50	3	47.5
4	53.5	55	53	4	51
5	56.5	60	54.5	5	54

\*Nails length in mm by sizes

## MUSTAD COPPER NAILS

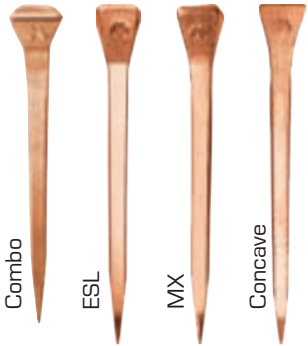

- Quality coating exceeds industry standards
- Copper coating prevents rust which eliminates discoloration around the nail holes
- Available in the most popular styles to fit a variety of shoes



Concave		MX		ESL		Combo	
Size	Length	Size	Length	Size	Length	Size	Length
3	50.5	50	50	3	47	5	59.5
4	53.5	55	53	4	51		
5	56.5	60	54.5	5	54		

\*Nails length in mm by sizes

## MUSTAD SLIDER 4.5



44 mm

The Mustad Slider 4.5 nail brings performance and efficiency to the Reining Circuit.

- Flat head
- Made to fit flush with plates
- Avoids the need to rasp nail heads
- Secures a locking fit with most sliding plates
- Saves time

## HAMMERHEAD™

The Racenail Revolution



- Specially designed, wide rectangular head for added durability throughout the full shoeing cycle
- The distinct neck and head waffle design, combined with the exclusive Mustad Pitch™ technology, providing a safe locking solution into the shoe crease
- The perfect fit prevents any shoe movement and therefore limits hoof wall displacement
- A long slim shank that drives high when needed
- Clinches are strong and easy
- The sharp, exact point ensures a consistent drive, minimizing the hoof wall impact to an absolute minimum
- The HammerHead™ nail fits into all creased race plates punched for both CH and E nails

Mustad HammerHead™ is designed to fit all race plates

Size	Length in inches
0	1.61"
1	1.73"
2	1.85"



## Concave Nails

The Concave nail has a special head shape that prevents the nail from twisting in the fuller and nail hole. The longer slim and strong shank gives the option to nail higher when this is preferred or necessary. The concept of PITCH offers a small angle between the nail head and the shank which aids nailing at the correct angle, and reduces the pressure on the hoof wall.

- Extra length with slim design
- Perfect for Concave, Equi-Librium and Eventer horseshoes



### "E" Nails

European style nail for European and handmade shoes

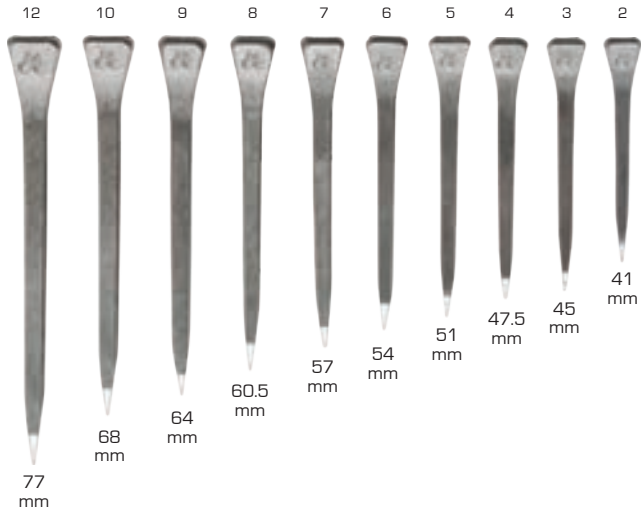

### "E" Slim Nails

European style for thin walls and brittle hooves.

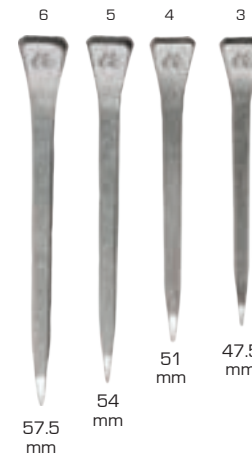

### Regular Nails

The traditional regular nail is especially suitable for heavy, pack and working horses.

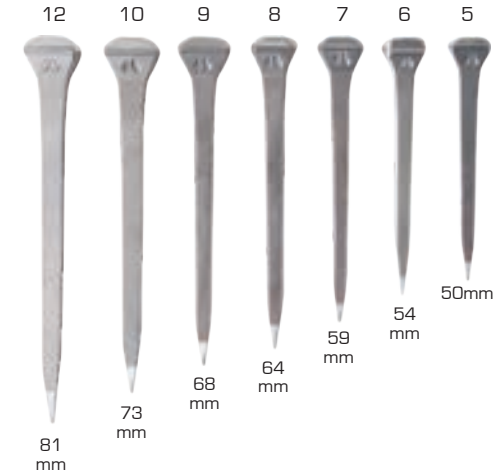

### Race Nails

For race horses.  
Good for thin-walled horses.

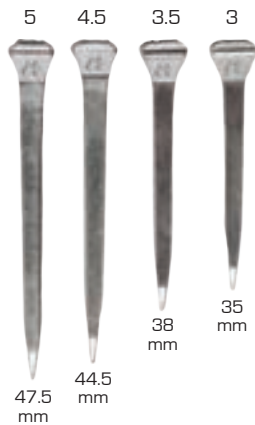

### City Head Nails

For use with saddle horses, working horses and ponies.



### Road E Nails

The Road Nail design is based on the E and E-Slim nails with the addition of a carbide pin in the head to reduce wear. Available in E and E-Slim nails.

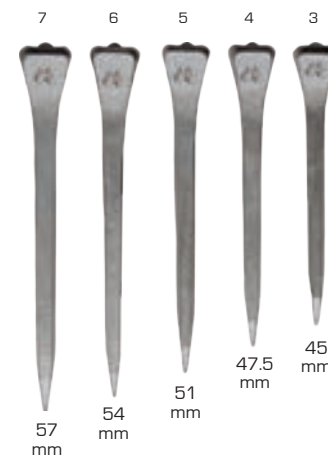

### Road ESL Nails





### Mustad MX Nails

For hand punched and European style shoes. Ideal for thin walled horses.

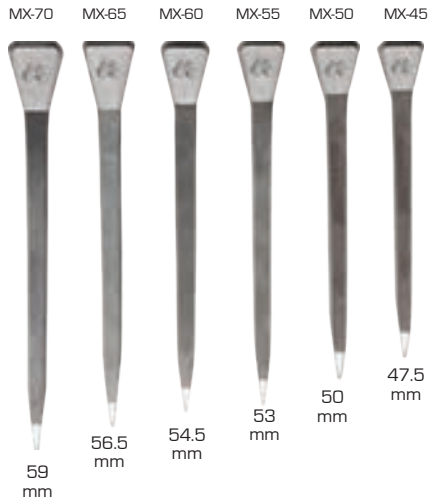

### Combo Nail

For handmade and foreign made shoes.



### ESL Pitch Nails

The E-slim nail is manufactured with a longer thinner shank than the standard E-nail so that it can be driven high with precision. The E-slim is ideal for horses with thin or brittle hoof walls.

- Drives & seats in line with the hoof wall angle, without adding unnecessary pressure
- Provides an unbeatable nail hole fit
- Ideal for horses with thin hoof walls
- Makes your work easier and more efficient



## DELTA COPPER NAILS

YOUR FAVORITE DELTA NAILS NOW AVAILABLE IN COPPER

- Copper coating prevents rust which eliminates discoloration around the nail holes
- Slim blade designed for smooth driving and less hoof displacement
- Engineered to lock you nail perfectly
- Point is sharp, precise and consistent

#### City Head Slim



#### Combo Slim



#### E Slim Blade



### City Head Nails

The Delta City Head nails are an excellent choice for a variety of shoes. They work especially well in drop forged shoes. They feature a sharp point, exact bevel and a slightly longer shank than other brands.

The Combo-5 Slim features a fuller shank where it meets the head, making it perfect for resets.

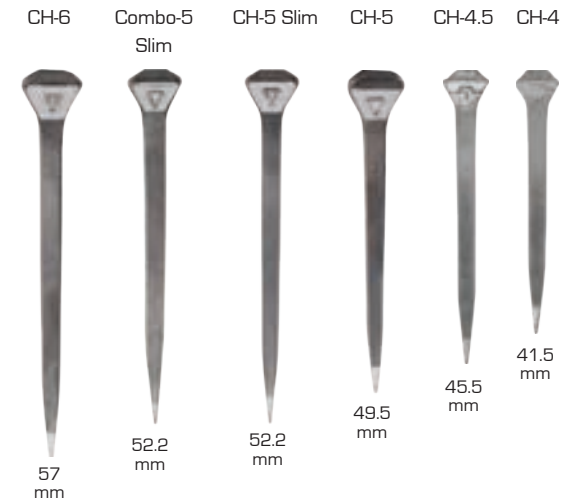

### “E” Nails

The Delta E nails are styled after the traditional European design and work well in both handmades and a variety of imported shoes. They feature a sharp point, exact bevel and a longer shank for more nailing options.

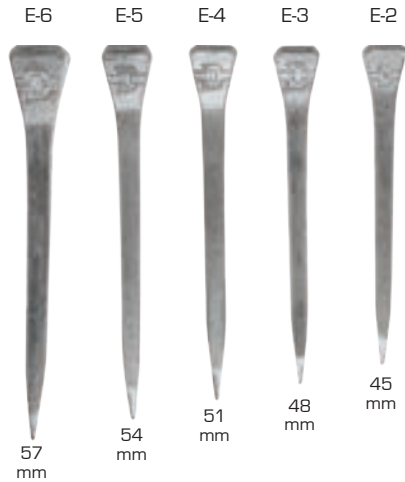

### E-Slim Blade Nails

The Delta E-Slim nails feature a more defined head and a much slimmer shank than the regular E nails, allowing them to be used in a wider variety of shoes, including ones punched for City Head nails.



### Race Nails

The Delta Race nails are the perfect choice for race plates. Also used on pony shoes and sliding plates, these nails feature a sharp point and an exact bevel for a consistent drive every time.



### Cooper “Lite” Nails

Slim blades which drive easier, have less hoof displacement and offer effortless clinching.





# HELLER RASPS

REACH FOR TRADITION

## eXcel LEGEND



# HELLER RASPS

Tradition Redefined

## eXcel LEGEND

- 10 % wider yet light and balanced
- Wider working area supports efficient hoof removal and leveling
- Legend teeth design now even more effective in wet conditions
- New multiglide file side ensures a smooth finish



# 32170

## eXcel ORIGINAL

- 10 % wider yet light and balanced
- Larger working surface for improved leveling, efficiency and control
- Coarse side teeth extended to the edges for rasping in clips
- More teeth per square inch than our standard rasps
- Performs in a variety of conditions



# 32169

## HELLER GRIP

- Unique design and texture increases grip and comfort
- Two versions to fit the full line of Heller Rasps including the new eXcel series
- Unique design and texture increases grip and comfort



black  
# 60080



red  
# 60081



blue  
# 60082 (eXcel)



green  
# 60083 (eXcel)

## PRO-FINISH by Heller



Heller's multiglide cut delivers just the right amount of hoof removal leaving a show quality finish. Its unique overcut avoids clogging. Heller's smoothglide side removes the slightest amount of material; leaving an overall polished finish.

- Finishes smoothly
- Leaves no rasp marks
- Provides a show quality finish
- Preferred by champions



# 32164

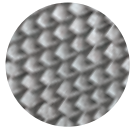

- # 32165  
14" Legend Rasp
- 100 % tested, inspected
  - Guaranteed to be tough
  - Easy to clean

### Legend

Features a larger tooth angle, resulting in a more open structure in the rasp. Well suited for softer, damper horn material which clogs a finely toothed rasp.

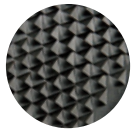

- # 32167  
14" Black Legend Rasp
- 100 % tested, inspected
  - Guaranteed to be tough
  - Easy to clean

### Black Legend

The Black Legend differs from the Heller Legend through the addition of a surface treatment that ensures the material is released from the rasp more easily and makes it more wear resistant.

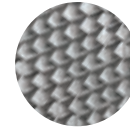

- # 32151  
14" Red Tang Rasp
- "The Red Tang rasp consistently performs to my expectations."  
- DAN HAUSSMAN, FARRIER

## Red Tang

A finely toothed rasp that removes material easily and is well suited for rasping hard, dry hooves.

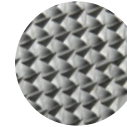

- # 32171  
17" Big Hoof Rasp
- Last long
  - Cut and glide easily
  - Offers a smooth finish

## Big Hoof

An extra long fine-toothed rasp. Length makes this rasp a good choice for extra large hooves. Fine teeth make it ideal for dry, hard hooves.

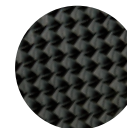

- # 32152
- Closer structure, ideal for rasping hard, dry hooves
  - 6 teeth per row
  - Ideal in dry weather conditions

## Black Master

Small teeth with a more concentrated pattern for an efficient cut in dry environments or for harder hooves. The Black Master features a special surface treatment at our Heller factory that prolongs the life of the rasp.





### Bellota Rasps & Tools

Product #	Description
31100	BELLOTA RASP TOP SHARP 6 pk/24 cs**
31101	BELLOTA RASP CLASSIC 6 pk/24 cs**
31105	BELLOTA RASP FINISH FILE**
41105	BELLOTA 6" FLAT FILE***
31106	BELLOTA RAPTOR RASP**
31107	BELLOTA MINI RASP W/ HANDLE
31108	RAZOR +PLUS RASP**
31109	BELLOTA FILE HALFROND 4003-14**
31111	BELLOTA FILE 4045-2CR-8****

Note: Pack size for Bellota Rasps  
 \* sold in pack of 4  
 \*\* sold in pack of 6  
 \*\*\* sold in pack of 12

### Sneaker Handles

Product #	Description
41630	SNEAKER RASP HANDLE BLUE
41631	SNEAKER RASP HANDLE ORANGE
41632	SNEAKER RASP HANDLE RED
41633	SNEAKER RASP HANDLE YELLOW



### Mustad Rasp Handle

The screw-on plastic handle fits our rasps, as well as any of your existing rasps.



### Double S Rasp End Covers

for Heller Rasps Aluminum # 40021  
 eXcel # 40036

### Double S Rasp Handle

for Heller Rasps Aluminum # 40022



Mustad horseshoe studs are made to the most exacting specifications and come in a wide range of styles to meet the grip requirements of all equine disciplines and environments. Designed by farriers in conjunction with competition riders. Mustad horseshoe studs offer performance, choice and durability at low prices. Mustad horseshoe studs are especially hardened during manufacturing to make the threads stronger and the tungsten pins are brazed to the body of the stud for better durability and strength over rocky terrain.

Ice studs made of steel with hardened body and welded tungsten carbide insert. Designed for riding and jumping on hard and rocky terrain. Grass studs are made of softer steel without tungsten carbide insert. Designed for riding and jumping on grass when extra grip is required.

Grass 1



Grass 2



Ice 3



Ice 4



Ice 5



Ice 6



Ice 7



Ice 8



### Screw In Studs

Product #	Tap	MM	Height Above Shoe MM	Pieces Per Box
70601 GRASS 1	3/8"	12	23.5	25/bx
70606 GRASS 2	3/8"	12	12	50/bx
70612 GRASS 2	3/8"	12	14	50/bx
70613 GRASS 2	3/8"	12	18	25/bx
70632 ICE 3	3/8"	12	15	50/bx
70640 ICE 4	3/8"	10	9.5	50/bx
70648 ICE 5	3/8"	10	11	50/bx
70654 ICE 6	3/8"	10	10	50/bx
70664 ICE 7	3/8"	12	9	50/bx
70676 ICE 8	5/16"	10	7.5	50/bx
70678 ICE 8	3/8"	12	7.5	50/bx
70680 ICE 8	3/8"	10	7.5	50/bx

### Mustad Drive-in Studs



P-10 S : P-11 S



P-11 1/2 : P-12 : P-13 S

With Mustad's carbide tip Studs, you'll see superior winter traction on ice, snow, mud and blacktop without time-consuming welds.

They last so long you can often reuse them on resets. Just punch the stud back out and you're ready to put it back in another shoe!

Type	Product #	Head Diameter MM	Height Above Shoe MM	Drill Bit	Pieces Per Box
P-10 S	70692	14	6.5	17/64"	50
P-11 S	70694	10	7.5	17/64"	50
P-11 1/2	70695	10	8.5	17/64"	50
P-12	70696	10		23/64"	50
P-13 S	70697	8		17/64"	50

### Plugits

Mustad Plugits® prevent debris from getting into the horse's heel area by plugging the stud hole. Plugits are treated with a rust preventive formula to give the ultimate in thread protection. Simply turn Plugits clockwise into the stud hole. To remove, pry them out with a pointed object to reveal a like-new stud hole.

# 80601



### Step 1. Drill

Simply select the correct drill bit size for the stud size from the chart and drill a hole in the shoe.



### Step 2. Drive

Place the stud in the hole and drive with a soft face hammer. (Do not use a hard face hammer as chipping may occur.) Do not drive it all the way to the other side of the shoe or until the shoulder touches the bottom side of the shoe.



### Ultra Lube Cutting Tool Lubricant

No-run formula, clings to vertical surfaces for continual lubrication



Item	Prod #	Packed
16 oz	35502	12 per case

### Sure Weld

A borax based compound to prevent oxidation while forging steel at high temperatures, making it easier to weld.



# 80702



### FARRIER TOOL RANGE

GDM Ball Clipping Hammer  
850 g / 1.8 lbs



# GDMB08

GDM Classic Forging Hammer  
900 g / 2 lbs



# GDMF08

GDM Pro Fit Forging Hammer  
850 g / 1.8 lbs



# GDMF18

GDM Elite Driving Hammer  
225 g / 8 oz



# GDMDH8



**FARRIER  
TOOL RANGE**

GDM Impact Starter Stamp  
# GDMPRSW



GDM Impact Fullered Stamp  
# GDMPCW



GDM Impact Plain Stamp  
# GDMPSW



GDM Master Fuller Standard  
# GDMSF



**FARRIER  
TOOL RANGE**

GDM Master Fuller Narrow  
# GDMNF



GDM Master Fuller Wide  
# GDMWF



GDM Clinch Gouge Right  
# GDMCGR



GDM Standard Pritchel  
# GDMPRIT







**FARRIER  
TOOL RANGE**



**FARRIER  
TOOL RANGE**

GDM Farrier Knife Curved Blade Right

# GDMKND



GDM Forging Hammer Handle

# GDMHR

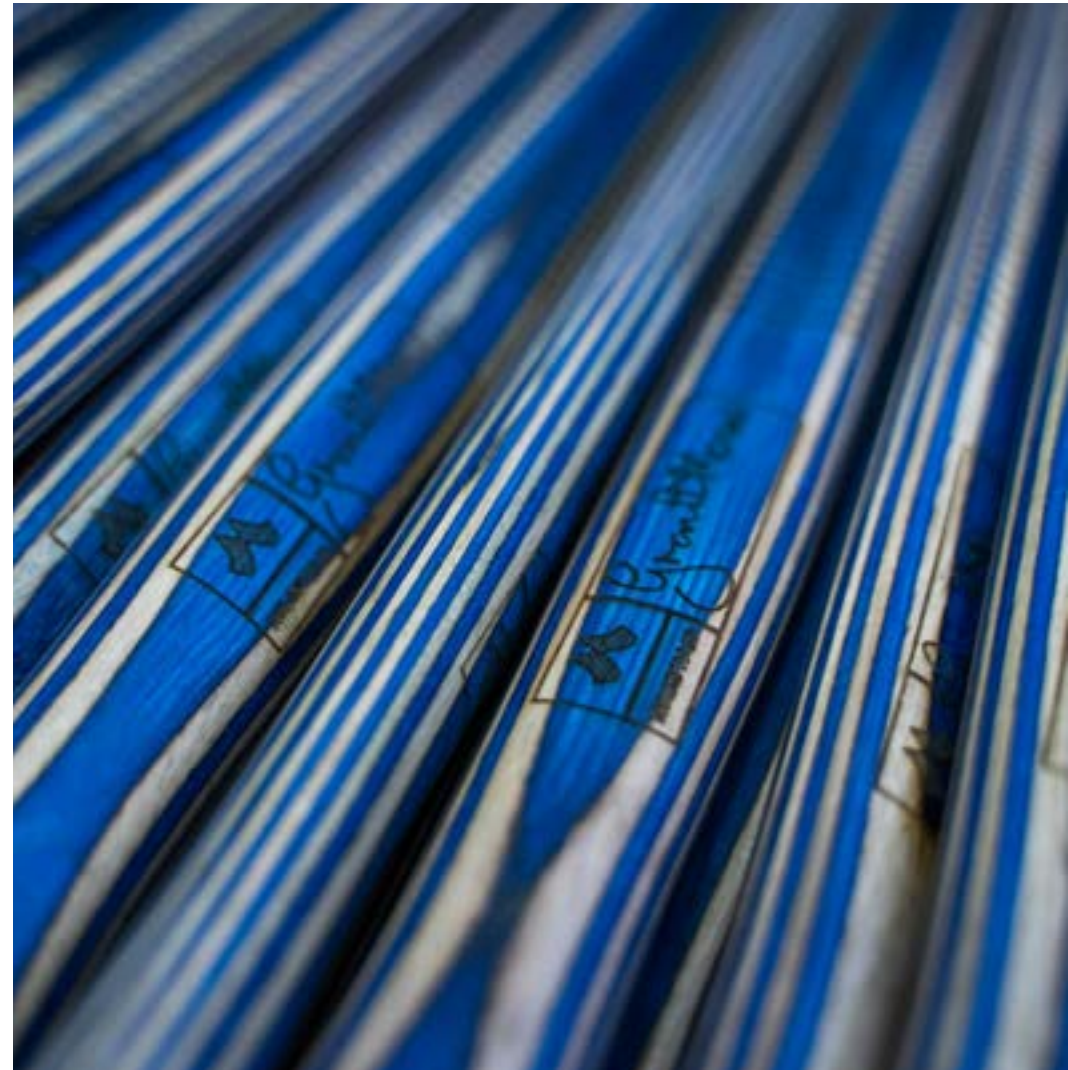

GDM Farrier Knife Curved Blade Left

# GDMKNSD



GDM Farrier Knife Straight Blade Right

# GDMKNLD



GDM Farrier Knife Straight Blade Left

# GDMKNLSD



### Nipper

Nipper performance sets the foundation for the overall success of your trim. The Mustad Premium Nipper features a unique Box Joint which is designed to maintain stability and accuracy through the long life of the tool. Mustad Premium Nippers are equipped with a precise cutting edge sharpness, tool strength, and durability. This nipper offers accurate cuts which reduces the amount of rasping required.



# 70020

### Ergo-Clincher

The unique design takes stress of your wrists and hands while clinching nails. The ergonomic angle and jaw design provides the ability to produce a tight flat clinch for every nail cut. The Mustad Premium Ergo-Clincher sets and secures the clinch with minimum impact on the hoof wall.



# 70075

### Pull-Off

This well balanced tool is as efficient as it is comfortable. The Mustad Premium Pull-Off is the very definition of form and function. Through its innovative design, it delivers the mechanical advantage required for effortless removal of the shoe.



# 70060

### Crease Nail Puller

Precision and Design are critical characteristics for a crease-nail-puller worth having. The fine, precise tip and the jaws make it easy to pull nails out of a variety of creases. The wide head design reduces the amount of force required when pulling nails.



# 70080



Mustad Tools are designed to bring comfort, performance and durability to the job. Mustad offers a wide range of tools to choose from in an attractive, blackened finish. Tools that work as hard as you do, day after day.

### Farrier Nippers



- 12" Farrier Nipper # 60032
- 14" Farrier Nipper # 60001
- 15" Farrier Nipper # 60015

### Pull-Off



- 12" Pull-off # 60062
- 14" Pull-off # 60003

### Nail Puller

- Nail Puller # 60017



### High Nail Clincher

- # 60047



### Clincher Blackened

- # 60005



### Low Nail Clincher

- # 60063



### Nail Cutter

- # 60034



### Mustad Forging Tongs



- 1/4 # 60019
- 5/16 # 60020
- 3/8 # 60021
- 1/2 # 60022

### Clinch Cutter # 60023



### Pritchel # 60046



### Clinch Block # 60066



### Mustad Forging Hammer



- 2lb [1oz] # 60050
- 2lb [5oz] # 60007
- 2lb [10oz] # 60049

### Mustad Forging Hammer Handle # 60011



### Driving Hammers



- Driving Hammer - 13 oz # 60009
- Light Driving Hammer - 11 oz # 60061
- Replacement Handle - 14 1/2" # 60012
- Driving Hammer 1 lb 1 oz # 60051

### Mustad Fore Punch

- City Head # 60036
- E Head # 60037



### Mustad Creaser

- City Head # 60038
- E Head # 60039
- Handle # 60070

# 60094



### Mustad Custom Hoof Knife

**Custom Hoof Knife Drop Blade**

# 60013	Left
# 60014	Right

**Hoof Knife Wide - Straight Blade**

# 60041	Left
# 60040	Right

**Double Edge Knife**

# 60042	Right
---------	-------



### Mustad Toeing Knives

For European style hoof trimming. Available in 11" and 14 1/2".

Toeing Knife 280 - 11" # 60025  
 Toeing Knife 360 - 14 1/4" # 60024



### Mustad Knife Sharpener



# 60026

### Kulp Spreader

Two different spreader sizes in one tool allowing adjustments from pony to warmblood size shoes. # 41438

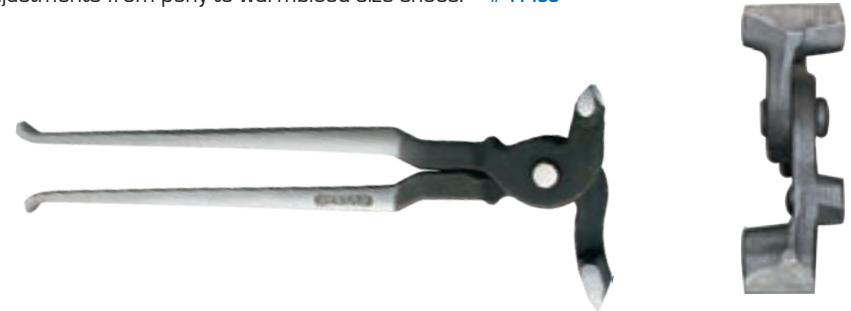

### Canvas Tool Bag

Holds up to 12 tools.  
 # 60099



### Ruidoso Hoof Gauge

The HG-1 gauge has an easily read guide with self adjusting design that lets you move from hoof to hoof without re-calibrating. Surface plate allows for easy leveling of entire perimeter of hoof plate.

# 41525  
 Repair Kit # 41526



### Delta Hoof Testers

Made from quality tool steel.

- # 41436 Large - 19" lg - 12" reins, Opens to 9.5"
- # 41437 Small - 13.5" lg - 9" reins, Opens to 5"



### Mustad Shoeing Kit

- Includes
- Mustad Clinch Cutter
  - Mustad Driving Hammer
  - Mustad Forging Hammer
  - Heller Rasp
  - Heller Rasp Handle
  - Mustad Shoe Puller
  - Mustad Clincher
  - Mustad Nail Pullers
  - Mustad Hoof Knife (RH)
  - 14" Mustad Nipper
  - Mustad Forging Tongs
  - Mustad Sharpener

Kit includes tools, tool box, and tips for safe horseshoeing guide.



### Mustad Trimming Kit

- Includes:
- Heller Rasp
  - Heller Rasp Handle
  - Mustad Hoof Knife (RH)
  - 14" Mustad Nipper
  - Mustad Sharpener

Kit includes tools, tool box, and tips for safe horseshoeing guide.



Edge Adjustable Hoof Tester

# 41421



Edge Curved Jaw Clincher

Tempered Steel

# 41423



Edge Clinch Cutter



# 41422

Edge Nippers

High quality chrome steel

12" # 41426 15" # 41429

14" # 41427



Edge Pull-Offs



Edge Hoof Knife



Economical knife manufactured with quality materials.

<b>EDGE Hoof Knives</b>	RH Knives
Narrow	# 41431

Double S Round Hammer

1.8 lb (800 g) # 40025  
 2 lb (900 g) # 40026  
 2.2 lb (1000 g) # 40027



Oval head

Double S Driving Hammer

6 oz (150 g) # 40028  
 7 oz (175 g) # 40029  
 8 oz (200 g) # 40030

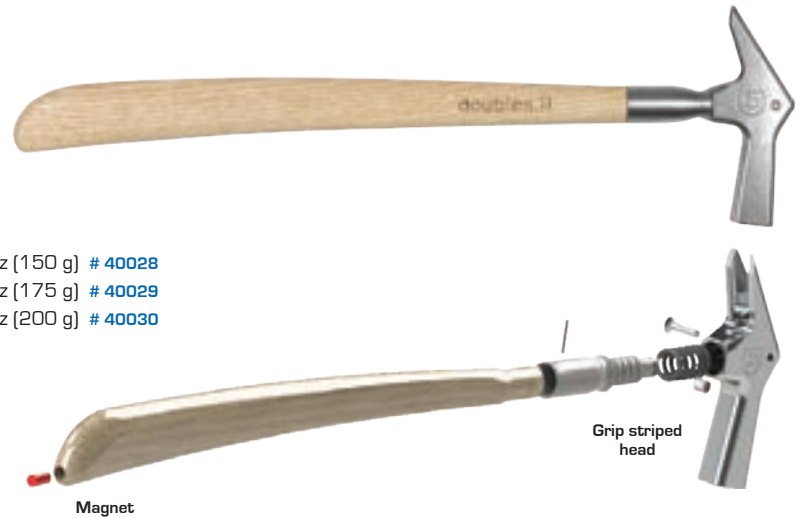

Grip striped head

Magnet

Double S Driving Hammer Handle # 40031

Double S Rounding Hammer Handle # 40032

Classic type



Available in right and left hand

- # 40003 RH Knife
- # 40004 LH Knife

Leo type



Leo Straight Blade. Available in right and left hand

- # 40005 RH Knife
- # 40006 LH Knife

Loop type



Loop Double Blade with long handle

- # 41586

Rhino type



Rhino Drop Blade and hoof-pick. Available in right and left hand

- # 40007 RH Knife
- # 40008 LH Knife

Classic Deluxe



Right/Left Hand - Drop Blade

- # 40009 RH Knife
- # 40010 LH Knife

Leo Deluxe



Right/Left Hand - Straight Blade

- # 40011 RH Knife
- # 40012 LH Knife

Rhino Deluxe



Right/Left Hand Drop Blade & Hoof Pick

- # 40013 RH Knife
- # 40014 LH Knife

“Loop Vet” Deluxe

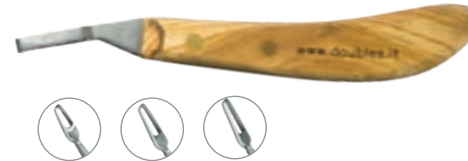

Right/Left Hand Drop Blade & Hoof Pick

- # 40015 Small
- # 40016 Medium
- # 40017 Large

Clinch Cutter type Right/Left Hand



- # 40001 RH Cutter
- # 40002 LH Cutter

Clinch Gouge type Right/Left Hand



- # 40018 RH Gouge
- # 40019 LH Gouge

Clinch Gouge Double type

- # 40000





Double S Hoof Pick

# 40020



Double S Combi

Right # 40023

Left # 40024



Double S Knife Vet Delux

# 40033



Double S 25A Hoof Knife

Right # 40037

Left # 40038



JB Pritchel

Made from S1 steel, heat treated to resist mushrooming and can be easily dressed for years of service.

Pritchel - City Head # 41252

Pritchel - E head # 41253



Gunnar Hammers

Designed to withstand rigorous daily use. Balanced and made from shock-resistant steel.



2 lb hammer

# 41234

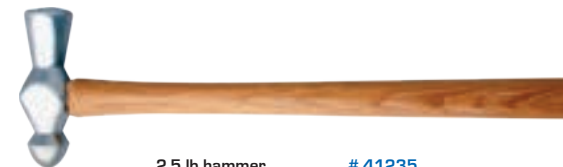

2.5 lb hammer

# 41235

Tongs

17" Fire Tongs, heavy duty rivet and built to last. Hot Fitting Tong has tapered ends shaped like a nail head to ensure tight hold on the shoe.

17"x1/4" # 41261

17"x5/16" # 41263

17"x3/8" # 41262



## Driving Hammers

Made from high-grade, shock resistant tool steel. Well-balanced with claws designed to easily ring nails.

- 8 oz # 41229
- 10 oz # 41230
- 12 oz # 41231
- 14 oz # 41232
- Repair handle # 41241



## Shaping Hammers

Well-balanced and made from shock resistant steel.

- 2 lb Rounding Hammer # 41236
- 2.5 lb Rounding Hammer # 41237
- Repair handle # 41243
- 2.5 lb Crosspien hammer # 41228



## GE TOOLS

**GE Nipper 14"**  
#41384



**GE Curved Jaw Clincher**  
#41373



**GE Low Curved Clincher**  
#41374



**GE Pull Off 14"**  
#41389



TFS has been in the anvil manufacturing business for several decades, providing quality anvils for the professional farrier and blacksmith. All are made in the USA., heat treated to exact specifications, and hand finished.

### Future 1

# 79526  
 Face 3.25"x14.75"  
 Horn 3.25"x12.5"  
 Height 9.25"  
 Base 7"x15"  
 Weight 86 lbs  
 1" hardie hole



### Future 2

# 79527  
 Face 4.25"x16"  
 Horn 4.25"x11"  
 Height 10"  
 Base 7"x15"  
 Weight 99 lbs  
 1" hardie hole



### Future 3

# RH - 79528  
 # LH - 79529  
 Face 4"x16.75"  
 Horn 4"x11"  
 Height 10.75"  
 Base 7"x15"  
 Weight 96 lbs  
 1" hardie hole



### Future 4

# 79530  
 Face 4.25"x17"  
 Horn 4"x11"  
 Height 10.25"  
 Base 7"x15"  
 Weight 96 lbs  
 1" hardie hole  
 Left handed anvil shown



### Future 5

# 79531  
 Face 4"x10.75"  
 Horn 4"x8.25"  
 Height 8.50"  
 Base 9.25"x11"  
 Weight 55 lbs  
 1" hardie hole



### Lil' Giant

# 79533  
 Face 4"x10.75"  
 Horn 4"x8.25"  
 Height 8"  
 Base 9.25"x11"  
 Weight 70 lbs  
 1" hardie hole



### Farrier 70

# 79538  
 Face 3.5"x12.25"  
 Horn 3.5"x9"  
 Height 7.75"  
 Base 8.5"x9.5"  
 Weight 70 lbs  
 1" hardie hole



### 100 Blacksmith

# 79520  
 Face 4"x14"  
 Horn 4"x9"  
 Height 8.5"  
 Base 7.75"x11"  
 Weight 100 lbs  
 1" hardie hole  
 1/2" round hole



### Farrier 100

# RH - 79539  
 Face 4"x16.75"  
 Horn 4"x10.75"  
 Height 9"  
 Base 9"x11"  
 Weight 100 lbs  
 1" hardie hole



### 150 Blacksmith

# 79521  
 Face 4"x16.5"  
 Horn 4"x10"  
 Height 10"  
 Base 8"x11.75"  
 Weight 150 lbs  
 1" hardie hole  
 1/2" round hole



### Farrier 125

# RH - 79541  
 Face 4"x17"  
 Horn 4"x11"  
 Height 10.75"  
 Base 8"x10.75"  
 Weight 125 lbs  
 1" hardie hole



### 200 Blacksmith

# 79522  
 Face 4.75"x18.25"  
 Horn 4.75"x11.25"  
 Height 10.75"  
 Base 8.25"x11.75"  
 Weight 200 lbs  
 1" hardie hole  
 7/8" round hole



### 300 Blacksmith

# 79523

Face 5.25"x19.75"  
 Horn 5.25"x12"  
 Height 12"  
 Base 10"x12.75"  
 Weight 300 lbs  
 1" hardie hole  
 7/8" round hole



### Smithy Special 4

# 79536

Face 6.5"x25.5"  
 Horn 6"x12"  
 Height 13.25"  
 Base 12.75"x13.75"  
 Weight 400 lbs  
 1" hardie hole  
 7/8" round hole



### 100 Double Horn Blacksmith

# 79525

Face 4"x17"  
 Horn 4"x9.25"  
 Height 8.5"  
 Base 7.75"x11"  
 Weight 100 lbs  
 1" hardie hole  
 1/2" round hole



### Smithy Special 2

# 79534

Face 5"x21"  
 Horn 5"x9"  
 Height 10.25"  
 Base 9.75"x12.5"  
 Weight 200 lbs  
 1" hardie hole  
 7/8" round hole





TFS Stall Jack  
# 79545



St. Croix Forge  
Steel Stall Jack  
# 79000

## Battlecreek Aprons

- Quality at a reasonable price
- A wide variety of color choices
- Years of comfortable, sturdy leg protection
- Designed to provide unrestricted movement

Item #	Style	Color	Size
45082	Standard	Gray Leg/Black Top/Orange Stitching	Regular
45084	Standard	All Black/Orange Stitching	Regular
45088	Standard	Royal Blue Leg/Black Top/Royal Blue Stitching	Regular
45093	Pro-Series	Gray Leg/Black Top/Orange Stitching	Small
45094	Pro-Series	All Black/Orange Stitching	Regular
45098	Pro-Series	Royal Blue Leg/Black Top/Royal Blue Stitching	Regular

### Standard



# 45082



# 45084



# 45088

## Edge Leather Apron Regular

# 45041



### BATTLECREEK ELITE

#### Pro-Series



Features back support  
and extra pocket on  
right leg

- Advanced micro adjustable belt system
- Includes support pad
- Improved airflow between layers
- Spark and abrasion resistant
- Sizes: small and regular



Small  
# 45101

Regular  
# 45100

YODER TOOL BOXES



Shorty  
# 41756



Classic  
# 41757



A strong brand, a strong history and wide variety of industry products - Mustad. You trust your horse's shoes and health only to the best brands. We provide the top lines of pads, boots, hoofcare health, prevention and nutrition products. The well-being of horses is what Mustad stands for and we continuously research the hoofcare field for the newest and best hoof care products.



### HOOF PAD

- Your “Must have” pad material to create comfort and protection
- Urethane-based, that sets in 30 seconds and sticks directly to a clean, dry sole
- Ideal with or without any kind of pads
- Optimal shock absorption, support and protection, enhancing the general condition of the sole, frog and hoof



### HOOF PAD SOFT

- Extra Soft Hoof pad material for very sensitive soles
- It sets in 30 seconds and affixes to clean dry soles
- Can be used with any kind of pad
- It seals the pad from any debris or moisture getting in between the pad and sole



### HOOF PAD ZNO

- Intended for wet conditions and helps prevent thrush
- Sets in 30-45 seconds
- Provides excellent cushioning and won't get as hard as competing brands
- Bonds to the hoof and will not allow air or humidity to get to the sole



### HOOF REPAIR BLACK

- Adhesive designed for large and small hoof repairs
- Bonds to most shoes
- Affixes to a clean dry hoof wall
- Sets in approximately 1 minute and hardens within 5 minutes while maintaining flexibility to ensure natural hoof movement
- Hardens to black color



### SILICONE

- It gives good protection and coverage of the sole
- This silicone sets within 3 minutes
- Can be used with any kind of pad
- It prevents debris or moisture getting in between the pad and the sole



### SUPER BOND

- It sets in 30 seconds and sticks to a clean dry hoof wall for small repairs
- Create a custom shoe for horses
- Perfect to glue on cuffs for foals or use with foal extension



Comfort 200 cc Dispenser



Mixing Tips



### No-Snow Pad

The Mustad No-Snow Pad has a unique air cushion that compresses, then expands to push snow out of the hoof, preventing dangerous snowball build-up and improving winter traction. Also a, great choice to prevent mud accumulation. No-Snow Pads are durable enough to handle tough winter conditions, can be easily applied during shoeing, and can usually be used in multiple resets.

- Improved shape fits most hooves and horseshoes
- Improved color makes it easier to locate horseshoes when they are lost in the snow



Item	Prod #	Packed
Mustad No-Snow Blue Front	80482	Pair
Mustad No-Snow Blue Hind	80483	Pair

### No-Shock Pads

Product #	Size	Prs/Case
80260	Small Full	10
80259	Large Full	10
80264	Bar Wedge 0	5

- Designed to relieve leg and tendon stress while offering good support
- Full pads offer sole protection when riding long hours
- Made with heavy duty polyurethane
- Wide variety of shapes and sizes for different applications



### Castle Therapeutic Pads

Product #	Size	Description
50144	5 3/4"x6 3/8"x.080"	Pour pad #4

### Castle Wedge Pads

Product #	Size	Description
50150	6 5/8"x6 3/4"x1/4"	#1 Degree wedge (black)
50152	5"x6 5/16"x5/16"	#2 Full wedge (black)
50156	6 1/2"x6 1/4"x1/2"	#3 Full wedge (black)
50101	1/4" at heel	#1 Bar wedge (black)
50102	3/8" at heel	#2 Bar wedge (black)
50103	1/2" at heel	#3 Bar wedge (black)





### Castle Flat Pads

Product #	Size	Description
50114	5 3/4"x6 3/8"x1/16"	Thinliner (black)
50115	5 3/4"x6 3/8"x1/16"	Thinliner (clear)
50112	5 3/4"x6 3/8"x1/8"	#4 (black)
50113	5 3/4"x6 3/8"x1/8"	#4 (clear)
50116	7 7/8"x7 1/4"x1/8"	#5 (black)
50117	8"x7 1/2"x3/16"	#6 (black)
50111	1/8" thick	Rim Pads, felt

### Castle Degree Pads

Product #	Size	Description
50151	5 5/8"x6 7/8"x3/16"	1 degree oval (black)
50155	5 7/8"x6 3/4"x7/32"	2 degree oval (black)
50158	5 7/8"x6 3/4"x7/16"	3 degree oval (black)
50153	7 5/8"x7 1/4"x5/16"	2 degree jumbo (black)
50154	6 3/4"x6 5/8"x7/32"	2 degree full long (black)

### Castle Snow Ball Pads

Product #	Size	Description
50149	6"x6 1/2"x1/8"	Regular (black)
50147	5 1/4"x6 1/4"	Rim, front (clear)
50148	5 1/4"x6"	Rim, hind (clear)

### Castle Hoof Print - Impact Pads

Product #	Size	Description
50132	6 3/8"x5 3/4"x3/16"	#4 Flat (green)
50133	7 1/4"x5 3/4"x3/16"	# 5 Flat (green)
50136	7 1/8"x5 1/8"x5/16"	#11 2 degree oval (green)
50138	7 1/8"x5 7/8"x7/16"	#15 3 degree oval (green)
50135	6 3/4"x6"x1/8"	Large Rim

### Castle Specialty Pads

Product #	Size	Description
50118	6 1/2"x5 7/8"x1/8"	Cushion frog pad, small (clear)
50127	6 1/2"x5 7/8"x5/16"	2 degree cushion frog pad (clear)

### Myron McLane Full Support Pad

Prod #	Item
80301	Support Small
80300	Support Full
80316	Bar Wedge Small #1
80317	Bar Wedge Medium #2



The pads transfer weight from the hoof wall to the frog, which relieves pain instantly in cases of under run and sheared heels, quarter cracks, laminitis, and pedal osteitis. Using the pads will keep your horse serviceably sound, while helping to correct heel problems in the long term. Full Support Pads are available in small and full, as well as small and medium Bar Wedge configuration. They can be used with egg bars, straight bars, and open shoes and be reused if problems reoccur.

### EZ Strider Pads

Prod #	Item	Packed
50501	Brown Large Rim	12pr./bx



### Shock Tammer Pads

Product #	Item
50200	Regular Pad
50203	Large Pad
50204	Rim Pad



Farriers Pride Pads

Product #	Description
#50223	Farriers Pride #1 Flat 3/32, 10pr Carton Ct20 10
#50224	Farriers Pride #2 Flat 1/8, 10pr Carton Ct20 10
#50225	Farriers Pride 1 Wedge/10 Pr Carton Ct20 10
#50226	Farriers Pride 2 Wedge/10 Pr Carton Ct20 10
#50228	Farriers Pride 3 Wedge/10 Pr Carton Ct20 10

Luwex MP AirRide Activator

# 90407



Luwex Premium Sport

# 90411 1 liter  
# 90412 4 liters



Luwex Premium Laminitis / Activator

Product #	Description
#90409	Luwex Premium Laminitis 1 L
#90410	Luwex Premium Laminitis 4 L
#90413	Luwex Premium Activator



Thrush Buster®

So powerful it lasts for up to eight days without reapplication... even in the wettest, muddiest terrain. Stomps out thrush on contact. A single application relieves agonizing, crippling effects of thrush and dramatically reduces chance of reinfection.

Packed: 24 - 2.0 oz bottles per case.

# 90010

\*Not sold in Canada



Tuff Stuff®

Hoof conditioner and toughener that's also a show quality cosmetic.

- Strengthens brittle, shelly, mushy or cracked hoof walls
- Protects scuffed toes and guards against fungus, caustics and bacteria
- Maintains the hoof wall's natural moisture level

Packed: 12 - 7.5 oz bottles per case.

# 90001

Hoof Shield

An all-natural hoof sealant formulated to maintain natural moisture level of the hoof. It forms a barrier to prevent brittle cracking in hot, dry conditions and soft, mushy hooves in wet conditions.



# 65015 Avail. 8 oz dauber bottle 12/cs

Hoof Marvel

All-natural hoof moisturizer that works incredibly fast to restore moisture to the foot. A real friend to the farrier who wants a workable hoof when conditions are extremely dry.



# 65030 1 gallon refill bottle 4/cs

# 65031 Avail. 32 oz spray bottle 12/cs



DELTA

High Performance Hoofcare Products

MUSTAD

High Performance Hoofcare Products



### Delta Hoof Boot

The Delta Hoof Boot provides all-terrain protection for both occasional and everyday riding. Easy to put on and take off, it stays securely on the foot. The high-performance urethane outsole provides maximum durability and shock absorbtion while providing traction similar to an unshod foot. Drainage holes keep the feet dry.

- Foam filled back flap and collar for added comfort and protection
- Raised inner rim offers built in sole relief
- Industrial grade velcro fasteners

Product #	Hoof Length	Boot Size
50250	4" to 4 1/4"	000
50251	4 5/16" to 4 9/16"	00
50252	4 5/8" to 4 7/8"	0
50253	4 15/16" to 5 3/16"	1
50254	5 1/4" to 5 1/2"	2
50255	5 9/16" to 5 13/16"	3



### Delta Hoof Boot Pads Flat & Wedge

Provides extra padding inside the Delta Hoof Boots. Each pad marked for easy trimming to fit the various sized boots.

Avail. Flat Pad # 50235  
Wedge Pad # 50236



### Delta Hoof Power

If you are treating a horse with "bad feet", it just needs the nutritional strength of Hoof Power. It is a pelleted, multi-nutrient hoof supplement containing generous amounts of high-grade biotin, methionine and ten other essential ingredients for strong, healthy hooves.

Product #	Size
90100	22 lb Tub
90101	40 lb Tub



### Magic Cushion



Product #	Size
65094	2 lb (6/case)
65098	4 lb (6/case)

### Sole Pack

Product #	Description
65060	SOLE PACK BULK 8LB CARTON CT4
65061	SOLE PACK BULK 4LB CARTON CT6

THE BEST EQUINE PRODUCTS  
TOGETHER FROM ONE COMPANY



**Mustad Hoofcare Center**  
907 SW 15th St. Forest Lake, MN. 55025  
Toll Free: 866-668-7642 Fax: 866-707-4642  
Phone: (651) 287-8289

[WWW.MUSTAD.COM](http://WWW.MUSTAD.COM)



**MUSTAD**

HOOF CARE CENTER, INC